

Perspective

Matrix Assisted Synthetic Transformations: A Mosaic of Diverse Contributions. II. The Pattern Is Completed

Derek Hudson

J. Comb. Chem., **1999**, 1 (6), 403-457 • DOI: 10.1021/cc990046s • Publication Date (Web): 09 November 1999

Downloaded from <http://pubs.acs.org> on March 20, 2009

More About This Article

Additional resources and features associated with this article are available within the HTML version:

- Supporting Information
- Links to the 1 articles that cite this article, as of the time of this article download
- Access to high resolution figures
- Links to articles and content related to this article
- Copyright permission to reproduce figures and/or text from this article

[View the Full Text HTML](#)



ACS Publications
High quality. High impact.

JOURNAL OF combinatorial CHEMISTRY

© Copyright 1999 by the American Chemical Society

Volume 1, Number 6

November/December 1999

Perspective

Matrix Assisted Synthetic Transformations: A Mosaic of Diverse Contributions. II. The Pattern Is Completed

Derek Hudson*

Biosearch Technologies, Inc., 81 Digital Drive, Novato, California 94949

Received August 27, 1999

Some see things as they are, and say "Why?",
A few dream things that never were, and say "Why not!"

Paraphrased from George Bernard Shaw,
Back to Methuselah
Act 1, Scene 1, 1921

Introduction

The reader is first directed to Part I of this Perspective,¹ in which the originators of many gel-type matrixes have described the development of their materials. In Part II, the story continues to unfold in the same manner. The focus of Part I was the introductory section by Bruce Merrifield; that of Part II is provided by a personal perspective from the other "father" of this field, Robert Letsinger, who independently conceived of solid-phase synthesis and pursued the concept, as applied to DNA synthesis, with equal vigor. His efforts provide the foundation for much of today's biotechnology. Truly we do stand on the shoulders of giants,² who dreamed of things that never were and made those dreams reality.

Table 1 summarizes some reasons why there has been so much interest in the development of new supports. Tables 2 and 3 provide an overview of the content of the two parts. Note, however, that the second contribution to Part II is a description of traditional gel form PS beads made with some novel technological improvements. Each section is introduced

by personal remarks (D.H. comments). The final section consists of a discussion by Bing Yan and myself on a topic dear to our hearts: we know from the few studies that have been done that the rates and yields of particular transformations are highly dependent on the nature of the matrix. These studies provide some clues as to which would be the best selection for any reaction series.

As with Part I, all contributors were given similar instructions: to prepare a personal account of their support development work, focusing on how the structure of the support influences its suitability.³ The opinions and comments provided by the contributors are, obviously, their own, and occasionally they are in conflict with statements by myself and others (since no contributor has had access to other contributions). I have on several occasions had to suggest modifications to authors, but I have never sought to influence their opinions; differences of opinion are not uncommon in this field and are part of its considerable fascination. I do, however, take full responsibility for encouraging candor, humor, and personal comments; attributes rarely found in conventional reviews!

* E-mail: dhudson@solidphase.com.

Table 1. Reasons To Develop Alternative Supports to Simple Gel-Type PS

Reason	Example
1. To permit flow through column reactor design	e.g. CPG, PS-PEG's, encapsulated resins, macroporous supports
2. To improve solvent compatibility	As above, + PDMA, Arshady variants
3. To improve reagent compatibility	CPG, Aspect, SPOCC
4. To access alternative targets, e.g. DNA	CPG, PS-PEG's, Aspect, macroporous supports (PS and polymethacrylate)
5. To provide improved synthesis efficiency for "combinatorial" targets, and to simplify transfer of reactions from solution to solid-phase.	????????
6. To provide on support display for bio-recognition processes	PS-PEG's?????, PEGA, Aspect, CPG, silica & glass (Affymax), <u>poly-methacrylates</u>
7. To permit alternative manipulation	Pins and crowns, MicroTubes (Irori) MacroPhase beads (ParaMatrix), cotton
8. To facilitate techniques in which reagents or scavengers are immobilized	Macroporous supports, Monoliths (e.g. Sherrington)
9. Environmental Considerations	Immobilized catalysts

Table 2. Selected "Gel" Supports Used for MAST³⁴ Discussed in This Perspective, Parts I and II

Type	Common Features	Representatives	Comments	Originators (Contribution in bold)
Gel (microporous)	High capacity Differential solvent swelling Reagent access by diffusion Uniform sites Many unsuitable for column reactors	1 or 2% crosslinked polystyrene,	Useful for peptide, and MAST in general	Merrifield Glettig
		Pepsyn, low crosslinked polyacrylamides	Peptide, and bead based libraries	Atherton, Sheppard , Arshady
		"Sparrow" resin	Very similar to Pepsyn, useful for direct antibody production	Sparrow
		Polyacryloylmorpholines	Peptide synthesis	Epton
		PEGA, SPOCC resins,	Based on crosslinked PEG; excellent aqueous compatibility	Meldal
		Sephadex LH 20	Based on crosslinked dextran	Erickson and Merrifield
		CLEAR	Highly polar resin	Kempe and Barany
Copolymers	May be gel or macroporous	Amphiphilic poly(styrene-acrylamide)s	General solvent and substrate compatibility, potential not fully realized.	Arshady (see also Merrifield)
Encapsulated Gel	Lower Capacity	Pepsyn K (acrylamide resin encapsulated in inorganic "cage")	Excellent for flow though Fmoc mediated peptide synthesis	Sheppard
	Column compatible Unstable to agitation	PolyHIPE (similar resin encapsulated in PS "shell")	Advocated for high-load peptide synthesis	Sherrington & Small

Table 3. Selected Modified Supports Used for MAST,³⁴ Discussed in Part II

Type	Common Features	Representatives	Comments	Originators (Contribution in bold)
Composite Particles	Reactions may be subject to hindrance by physical limitations of either component, and of the tightly packed nature if linear polymer coat	PS coated Kel-F	Early support for peptide synthesis produced by radiation grafting	Tregear
		PS coated PE	PE-PS, analogous material on PE particles	Hudson
			MacroPhase Beads for MAST	ParaMatrix, Tucson
		Composite containing magnetic particles	Product of Solid-Phase Sciences	Sucholeiki
Pellicular beads	Very Low loading	PS	Useful for DNA synthesis	PE-Biosystems
Graft Copolymers	Lower Capacity More uniform swelling Pressure stable Column compatible	PEG-PS	Prepared by addition of PEG block	Barany
		Tentagel	Prepared by polymerization of ethylene oxide onto resin, monosized beads useful for library applications	Rapp Polymere, Bayer and Rapp
		Argogel	PEG attached via branched diol support	Gooding, Labadie, Porco (Argonaut)
		Champion, NovaGel	Various formulations prepared from PEG blocks	Biosearch Technologies Calbiochem- NovaBiochem, Hudson
		Dendrogel	Branched PEG chains	Hudson
		Dendritic polymers	Prepared by assembly of dendrimers on standard PS gels	Bradley
Rigid MacroPorous Supports	Capacity and efficiency depend on specific surface area, mean pore volume, pore distribution, and mean pore size	High-crosslinked PS	Small pore versions excellent for MAST (e.g. ArgoPore)	Gooding, Labadie, Porco (Argonaut)
			1000 Å pore versions good for DNA synthesis	Andrus
		Polymethacrylates	Bead based peptide libraries DNA synthesis	Buettner Reddy
		CPG, silicas	Support of choice for DNA synthesis, MAST? Useful for enzyme inhibitor libraries.	Adams Morgan
		Poros, "Perseptive Biosystems" Primer, Pharmacia	Novel HPLC materials which have been used for DNA and peptide synthesis	Kates
		Aspect	Porous PE produced by vigorous oxidation	Cook & Hudson
Modified Surfaces	Low capacity except if coated with highly substituted functional polymer	PE-PS films	Can use film handling techniques for proces	Merrifield, Tam
		Derivatized linear PS	Modified Microtiter plates	Clark
		PS coated PE/PTFE MicroTubes	Used with Rf transponder for tracking	Zhao , IRORI
		Cellulose	"Spot" method of peptide synthesis, epitope mapping	Frank
		Cotton	In centrifugal reactors	Lebl
		Glass	Array Applications (Peptide and DNA)	Affymax, Hoeplich
		Plasma aminated PE	"	Beckman
		Grafted PE "pins" and "crowns"	Epitope mapping, SPOS	Geysen, Maeji , Rodda
		Dextran coated PE discs	Pilot library technique	Hudson
Membranes	DNA and peptide synthesis	Daniels , Millipore		

Robert L. Letsinger.⁴ Reflections on Solid-Phase Synthesis

Solid-phase synthetic methodology exploits insoluble supports as carriers for synthetic intermediates. Transformations in a multistep synthetic sequence are effected in successive cycles involving addition of reagents to a substrate immobilized on a support followed by washing to remove excess reagents and soluble byproducts. At the end of the synthetic cycles, the anchor linking the substrate to the support is usually cleaved and the product isolated and purified. In some applications, however, the product may be utilized while still bound to the support. This methodology, developed in the early 1960s,^{5,6} has had a profound influence on synthetic chemistry and, by enabling facile, automated synthesis of polypeptides and polynucleotides, has had a major impact on much research in biology and medicine. In the present account, I provide a personal perspective on early work in my laboratory in this area.

The concept for solid-phase synthesis originated in my case from a perceived need for the technology and some experimental evidence suggesting its feasibility. In the early 1960s I decided to explore some new approaches to oligonucleotide synthesis. This research marked a new direction for the laboratory since our previous experience had been largely in the areas of organometallic, polymer, and boron chemistry. At that time, the polynucleotide field was largely ignored by organic chemists, methods for synthesis, isolation, and characterization were very labor-intensive, and applications for synthetic oligonucleotides appeared limited. However, chemistry based on oligonucleotides offered intriguing opportunities for designing self-assembling systems since the rules for association of complementary strands were well understood, and one could have faith that, as segments of giant polymers encoding the information of living systems, oligonucleotides would prove important as tools in chemistry and biology. The pioneering work of Todd⁷ and Khorana⁸ provided strategies for constructing oligonucleotides from nucleosides and nucleotides and for protection of base groups during the condensations. It was clear, however, that even if rapid and efficient couplings could be realized, the need to recover products at every stage of the synthesis would make procedures for solution-phase synthesis of large polynucleotides very time-consuming. Similar considerations applied for polypeptide synthesis. Techniques were needed to reduce the labor involved in the repetitive step syntheses of these natural polymers.

The experimental backing for a solid support approach was provided by earlier studies in my laboratory showing that (a) relatively large organic molecules such as diethyl tartrate, ephedrine, and *o*-phenylenediamine could be bound covalently to insoluble polymers functionalized with boronic or borinic acid groups, (b) excess reagents could be separated by a simple washing step, and (c) the reactants could be recovered by hydrolytic cleavage of the B–O or B–N bonds that had formed.⁹ Both a fluffy popcorn copolymer prepared from styrene, diallyl maleate, and the (+)-diethyl tartrate ester of *p*-vinylbenzenboronic acid and a highly cross-linked, nonswelling polymer obtained by radical polymerization of styrene and 2-aminoethyl bis-*p*-vinylphenylborinate proved

effective as supports for immobilization of the aromatic compounds. This chemistry demonstrating that organic molecules could be taken up from solution by reacting with functional groups on insoluble polymers provided the seed for the idea that insoluble polymers could serve as carriers for intermediates and products throughout a multistep synthetic sequence.

Our initial test⁶ of the solid-phase approach was directed to preparation of a peptide since the chemistry for linking amino acids appeared more tractable than that for linking nucleotides at the time. A carboxylated popcorn polymer derived from styrene (99.5%) and divinylbenzene (0.5%) was employed as the support. As a very low density yet structurally strong insoluble polymer, it appeared attractive as a carrier for substituents reacting with soluble reagents. We found that the pendant carboxyl groups could indeed be converted essentially quantitatively to hydroxymethyl groups, acid chloride groups, or methyl esters by treatment with lithium aluminum hydride, thionyl chloride, or diazomethane, respectively. For the peptide synthesis, the hydroxymethylated polymer was treated successively with phosgene, leucine ethyl ester, aqueous sodium hydroxide, isobutyl chloroformate, and glycine benzyl ester. At each stage the polymer was filtered and washed to remove excess reagents and soluble products; then, in a final step the polymer was treated with hydrogen bromide to cleave the benzyl ester and release the product.^{6,10} The recovery and characterization of leucylglycine demonstrated the validity of the solid-phase synthetic concept. As is frequently the case in science, the time was ripe for the new approach. At this stage in our research, Bruce Merrifield, who had been working independently on solid-phase peptide synthesis, reported the synthesis of a tetrapeptide by a solid-phase method.⁵ He subsequently elaborated the chemistry to provide an elegant general route for automated synthesis of polypeptides.

For synthesis of oligonucleotides the key questions concerned the transport of nucleoside derivatives to and from functional sites on the polymer, procedures for anchoring nucleosides and releasing the oligonucleotide products, and the chemistry to generate the internucleotide linkages. Since the solid-phase approach precludes isolation and purification of intermediates, very high coupling yields are essential if extended chains are to be made. Moreover all reactions in the repetitive steps should be mild, to avoid side reactions on the synthetic intermediates, and fast, to facilitate synthesis of long polynucleotides or many short oligonucleotides. The available chemistry, developed for syntheses in homogeneous solution, did not satisfy these conditions. The first synthesis of a dinucleotide containing a natural 3'-5' internucleoside link utilized condensation of a nucleoside phosphorochloridate with a nucleoside to form a phosphotriester triester that was subsequently converted to the phosphodiester.¹¹ This triester approach was superseded by a "phosphodiester" approach in which the desired internucleoside links were formed directly by condensations at nucleoside phosphoryl and hydroxyl groups.⁸ The yields for both approaches were variable and often low, and the reactions were relatively slow. In retrospect, fulfilling the need for an efficient and rapid coupling chemistry proved to be the major challenge in

developing a practical solid support methodology for synthesis of oligonucleotides.

In our first work with nucleosides,^{12,13} 5'-O-trityldeoxycytidine was linked through the amino group to carbonyl on a popcorn polystyrene support, the 3'-hydroxyl group of the attached nucleoside was phosphorylated with β -cyanoethyl phosphate, and the resulting phosphodiester was activated with mesitylenesulfonyl chloride and condensed with thymidine. The product could be released as 5'-O-trityldeoxycytidylthymidine at that stage by alkaline treatment or extended to the trinucleotide or tetranucleotide stage by repetitions of the phosphorylation and condensation steps. The yields were modest at best (53% for the dinucleotide and less for the others); however, the experiments showed that nucleotide oligomers could indeed be synthesized on and released from an insoluble support. Related experiments showed that dG as well as dC, T, and dA could be transported to active sites on the insoluble polymer¹⁴ and that the 3'-OH and 5'-OH groups of the nucleosides could serve as anchor sites.¹⁵

The coupling chemistry here was novel in that a cyanoethyl nucleoside phosphodiester rather than a nucleoside phosphate was activated for the condensation step. This procedure was designed to generate a protected internucleoside phosphoryl linkage that would be inert during subsequent phosphorylation reactions yet afford a phosphodiester on treatment with alkali. Working with intermediates on solid supports, however, is somewhat like working with objects in a black box. One can easily see what goes in and what comes out but not what is going on inside. To clarify the chemistry and explore the potential for this triester approach for solution-phase as well as solid-phase syntheses, we prepared and characterized the cyanoethyl phosphotriester derivatives of TpT, TpTpT, and TpTpTpT using pyridine as a solvent, 5'-O-methoxytritylthymidine 3'-cyanoethyl phosphate as the phosphorylating entity, mesitylenesulfonyl chloride as the activating agent, and thymidine as the initial nucleoside.^{16,17} The expected cyanoethyl phosphotriesters derivatives were obtained as white solids in reasonable yields. They were stable in neutral solvents and, as hoped, afforded the natural phosphodiesters quantitatively on brief exposure to ammonium hydroxide. A nice feature was that the phosphotriester derivatives could be handled by conventional techniques of organic chemistry, such as extraction into organic solvents and flash chromatography on silica. As a consequence the process could be readily scaled up to prepare them in multigram quantities. Improvements in yields for both solution-phase and solid-phase syntheses were achieved by introduction of a β -benzoylpropionyl protecting group for protection of the 3'-OH of the incoming nucleoside.^{18,19} *p*-Methoxytrityl, β -benzoylpropionyl, and β -cyanoethyl served as a useful set of orthogonal protecting groups for the 5'-OH, 3'-OH, and P-O groups, respectively. Each could be unblocked selectively in the presence of the other two. The *p*-methoxytrityl ether was cleaved with weak acid, the β -benzoylpropionyl ester with hydrazine in acetic acid/pyridine, and the β -cyanoethyl phosphotriester with ammonium hydroxide.

Many research groups contributed to the subsequent elaboration of the solid-phase and phosphotriester approaches for synthesis of oligonucleotides.²⁰ Several practical methods are now available for synthesis of oligomers with any desired sequence. The most efficient procedure, and the one almost universally employed today, is a solid-phase phosphite triester method utilizing phosphoramidite reagents. The chemistry for this method is based on three further innovations: development of the phosphite approach for oligonucleotide synthesis (Letsinger et al.^{21,22}), use of silica-based solid supports (Matteucci and Caruthers,^{23,24} Ogilvie and Nemer²⁵), and introduction of nucleoside phosphoramidites as the P(III) reagents (Beaucage and Caruthers²⁶).

Phosphite Chemistry. An ongoing goal of the research in my laboratory in the early 1970s was the discovery of new and better chemistry for constructing oligonucleotides. The door for the phosphite approach was opened by our observation of the remarkable reactivity of diethyl phosphorochloridite [(EtO)₂PCl] in phosphitilating the 3'-OH group of a 5'-O-protected thymidine.²⁷ Under conditions where phosphorylation with diethyl phosphorochloridate [(EtO)₂P(O)Cl] required several hours, phosphitilation with the P(III) reagent was complete within a minute. To exploit the reactivity of trivalent phosphorus reagents in the synthesis of oligonucleotides, we needed a fast, efficient, and mild means for oxidizing trialkyl phosphites to the corresponding phosphates. The available methods did not appear satisfactory. However, a clue for a mild oxidation was provided by a paper reporting that iodine reacts rapidly with triethyl phosphite to give diethyl phosphorochloridate and ethyl iodide.²⁸ Consideration of a plausible mechanism for this reaction indicated that water might intercept the intermediate and afford a trialkyl phosphate. Experiments to test this idea showed that trialkyl phosphites could in fact be oxidized quantitatively within seconds by iodine in wet solvents containing pyridine.²¹ With this chemistry in hand we were able to elaborate a rapid method for coupling nucleotides stepwise.²² The key steps for chain extension were preparation of an active monomer unit by selective phosphitilation of a 5'-O-protected nucleoside [Nuc-OH] with a phosphorodichloridite [ROPCl₂], condensation of this unit [Nuc-OP(R)Cl] at the 5'-OH group of a protected nucleoside or oligonucleotide, and oxidation with iodine/water to convert the phosphite triester intermediate to a phosphotriester.

Silica Supports. Caruthers^{23,24} and Ogilvie²⁵ selected silica gel as a support in adapting phosphite chemistry to solid-phase synthesis. This proved to be a good choice. The silica-based supports are rigid and do not swell or contract in solvents employed in the synthetic cycles, and reagents and products can diffuse rapidly in and out of the pores. These aspects are particularly relevant for syntheses using phosphite chemistry since several transfer steps are made in each cycle to add a nucleotide unit and the cycle time is of the order of only a few minutes. Silica gel has since been replaced by controlled pore glass (CPG) as the support of choice. CPG supports are now available commercially in pore sizes optimized for the size of the oligomer to be made (500 Å for <30 nucleotides, 1000 Å for 30–150 nucleotides, and 2000 Å for >150 nucleotides). A convenient technique for

carrying out the synthesis of a short oligonucleotide manually utilizes a syringe equipped with a filter pad to hold the support.^{29,30} Reagents and solvents for extending the chain are brought in and expelled simply by manipulating the plunger.

Phosphoramidite Reagents.²⁶ Phosphorochloridite chemistry enabled rapid synthesis of oligonucleotide in a chemical laboratory environment; however, the P(III) nucleoside building blocks required careful handling since they are very sensitive to moisture. An improvement that made phosphite chemistry convenient and generally applicable was replacement of $-Cl$ in the nucleoside P(III) intermediate [Nuc-OP(OR)Cl] by $-NR'_2$.^{26,31} The nucleoside phosphoramidites [Nuc-OP(OR)NR'_2] are stable in the presence of water and can be prepared, isolated, and stored in bottles until needed. Yet on treatment with mild acid they become very reactive phosphitylating agents, comparable in reactivity to the nucleoside phosphorochloridite reagents. This phosphoramidite chemistry of Caruthers capped the chemistry developments needed for automated synthesis of DNA.^{31,32} One can now fill bottles on a DNA synthesizer with reagents and solvents, attach a cartridge containing a nucleoside immobilized on a solid support, type in the desired nucleotide sequence, press a button, go to lunch, and return to collect the oligonucleotide.

Solid-phase synthesis of oligonucleotides and modified oligonucleotides has become a routine activity for many laboratories throughout the world. Hundreds of thousands of different structurally defined oligonucleotides are made annually for use in research and medicine. Since very small amounts are needed for most applications in biology, syntheses are typically run to give 0.2 or 1 μmol of an oligonucleotide. The scale can be vastly different, however. "DNA chips" for genome screening and diagnostic applications have been prepared that contain hundreds of thousands of different oligonucleotide probes anchored at discrete and known sites within a 2 cm^2 surface area,³³ and methods are in place for producing multi-kilogram quantities of chemically modified oligonucleotides for use as therapeutic agents. One can predict with confidence that chemically synthesized oligonucleotides will play an increasing role in science, medicine, and society.

Gel-Type PS Resin

D.H. comments: To start with, we return to the topic of gel-type PS beads. These materials have been the work horse of most MAST³⁴ applications and have undergone only minor tuning since their development for synthesis, as described by Merrifield in Part I. Polymer Laboratories has been in the vanguard of the movement to commercialize resins based on in situ polymerization of functional monomers, i.e., by the use of 4-chloromethylstyrene along with styrene and divinyl benzene in the suspension polymerization process. Willi Glettig provides both insightful general comments and a description of new variations developed by his company which apply this idea, and several technological improvements, to the preparation of monodisperse beads of any particle size. Similar processes, in all probability, are the basis of the resin from Rapp Polymere, as discussed later.

In our hands, conventional large beads, in plain or PEGylated guises, do work well, but they suffer from stress under synthesis conditions, which may result in a small but significant amount of fragmentation.

Willi Glettig.³⁵ Reproducibility and Quality—Key Factors for Future Success of Combinatorial Chemistry

The ultimate goal for medicinal chemists is to synthesize libraries containing a large number of single compounds for lead discovery; this approach is fertilized by many useful strategies. The recently introduced sort and combine methodology with electronic tags for tea-bags, cans, and pins (by different research groups) allows the production of single compounds in milligram quantities; these examples represent only a minor selection from many other technologies described in the literature. Besides the indisputable value of producing these quantities for archiving and long-term testing strategies, many arguments arise against the production of milligram quantity of compounds for large lead finding libraries known for low hit rates. As well as stability concerns, economical reasons have to be considered when producing large libraries with 30 000 to 100 000 components in milligram quantities with the above technologies.

The split and mix methodology, introduced by Furka, is a valuable alternative to produce large libraries consisting of single compounds on individual beads. With this technology the compounds are produced on beads, depending on the size and the total number of beads used to synthesize the library. Today's assay technologies, e.g., high-density plates, facilitate measurement, since several copies are required to ensure all components are present at least once. Despite this redundancy and the need for encoding, this synthesis strategy seems to be more economical since the consumption of building block reagents and solvents used in producing the library is very much less than in the other solid-phase synthesis methods.

A chemist once joked that chemical engineers function only if they have a problem to solve. When I first met Peter Schneider³⁶ (Novartis Pharma AG), a creative combinatorial chemist, he presented us with a complex problem. He was after precise solid-phase resins for use in single bead synthesis. As a former polymer chemist I knew the global polystyrene manufacturing industry reasonably well. Peter wanted the impossible, a kind of a macromolecular rack with precise dimensions into which he could pack large quantities of small molecules. Peter's aim was clear—he wanted to move his department toward one bead one compound synthesis followed by on-bead assay to manufacture very large libraries. The motive behind this miniaturization strategy was sound—to reduce the cost of reagents and solvents and to increase production rates. More importantly his strategy carried the promise to reduce drug discovery time substantially!

Developing and manufacturing tools and processes, which reduce costs in research and development, have become our number one obsessions. Shrinking drug research and development time by 1 year means savings of \$40–80 million. It does not need a genius to see that a time reduction of only

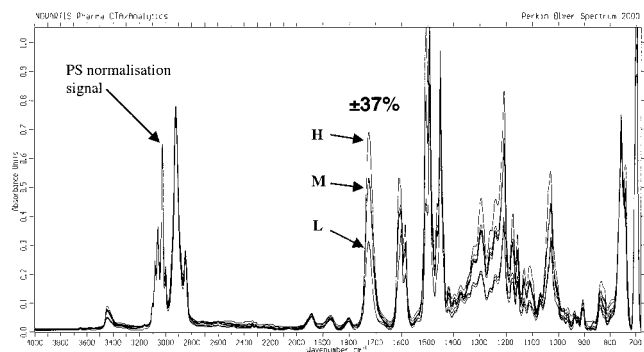

Figure 1. FTIR spectra of 11 single beads from a conventionally produced PS batch, transmission mode. The batch is clustered in three parts with low- (L), medium- (M), and high-loaded beads (H) with the relative ratio of 4:4:2.

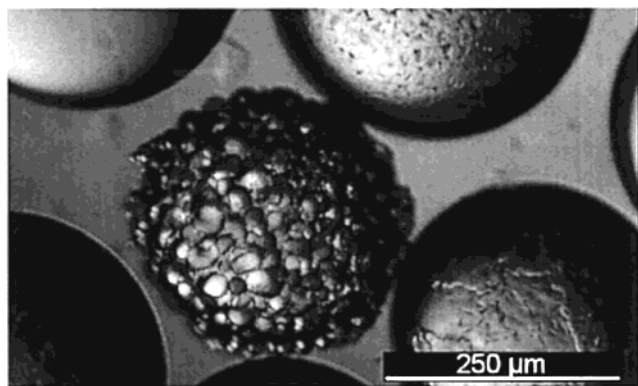

Figure 2. Photograph of optical microscope image of commercial PS beads, swollen in THF, of 70–90 mesh.

10–20% would have profound consequences for the future structure and evolution of the pharmaceutical industry. Peter's request was not only a complex technical challenge but also an opportunity to develop a tool which could contribute to substantial growth of the pharmaceutical industry.

In the following paragraphs I will try to summarize Peter's comments from many discussions. In 1995 his group formulated a new strategy to build a single compound/single bead technology platform comprising the needs for off-bead/on-bead testing. The most important demands to the chemists included the production of high-quality libraries and aiming for equal quantity of compounds released from each bead. This amount of compound should be sufficient to analyze the product and to be tested within several assays. A thorough analysis of the available polymers showed highly variable loading and large variations of bead sizes. Figure 1 shows the FTIR spectra of 11 single beads from a conventionally produced batch in transmission mode. The batch is clustered in three parts with low-, medium-, and high-loaded beads with the relative ratio of 4:4:2. Figure 2 shows a photograph of commercial beads, swollen in THF, of 70–90 mesh.

Both loading and bead size influence the quality, the reproducibility, and the amount of released compounds considerably. Consequently, optimal beads should be of equal size with no batch-to-batch variability, homogeneously loaded with linkers, and chemically defined (acting like a real protecting group not interfering with the planned chemistry). These futuristic characteristics would help the

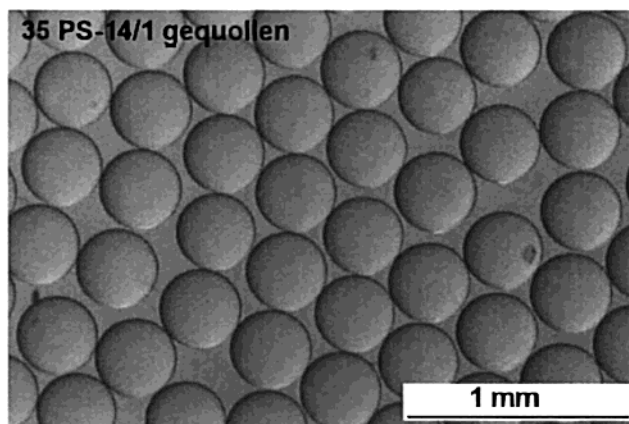

Figure 3. LCC-Dynospheres, swollen in THF, 200 μm in dry state.

chemists to achieve reproducible reaction kinetics and swelling properties to guarantee high yield and purity and predictable scale-up of compounds.

For my part, it seemed that the early days of combinatorial chemistry brought a euphoria about solid-phase combinatorial chemistry, and the comments made in the marketplace suggested that large quantities of resins would be required. To cope with that demand it was obvious that we had to align ourselves with a bulk resin manufacturer. Globally there are about six large scale, maybe another six medium scale, and many laboratory scale producers of polystyrene resins. However, there is only one large scale manufacturer with a proprietary process to manufacture very precise monodisperse beads (Dyno Particles, Norway). We approached Dyno in 1995 to form an alliance and to develop unique polystyrene beads for solid-phase synthesis applications. In 1996 a collaboration contract was signed and our project commenced.

Professor Ugelstad and co-workers invented a swelling technique to manufacture highly uniform monodisperse beads with a variety of different monomers. The principle of that process is to introduce into small polymer particles a relatively low molecular weight, highly water insoluble compound. If such particles, which partly consist of an oligomer water insoluble compound, are dispersed in a water/monomer mixture, swelling with monomers occurs until a semiequilibrium is reached. At this point the partial molar free energy of the monomer is equal in the swollen particles and in the pure monomer droplets. The swelling is increased 100–1000 times caused by the fact that the particles, which become swollen, are not pure polymer, but particles where part of the polymer has been replaced by an oligomer. Dyno has the manufacturing license to the Ugelstad process and has developed a wealth of know-how for manufacturing gel-type and porous-type perfectly uniform beads. Beads made by this proprietary process do not have to be sieved and have an even distributed matrix.

The big problem was that nobody had ever made large diameter beads with Ugelstad's process. Novartis helped us to partially finance the first attempt to manufacture large polystyrene beads. It took us roughly 6 months of development time to synthesize 200 μm diameter monodisperse particles. We called the new beads *LCC-Dynospheres*, shown in Figure 3. In a second phase, we investigated what level

of cross-linkage and morphology would be required to produce the best results in combinatorial chemistry. We made a range of gel-type and highly porous beads. Pore sizes were between 4000 and 5000 Å. We bought some competitive products and submitted half of our sample mix to a group of small molecule combinatorial chemists for evaluation. The second lot was submitted to an oligonucleotide synthesis chemist. On the basis of their comments we knew that the morphology in the beads was far from being ideal. Furthermore, we were convinced that macroporosity was not the way to go for manufacturing small molecules. To obtain macroporosity it was necessary to have highly cross-linked, rigid particles. By increasing cross-linkages we brought into the polymer structure undesired impurities including free double bonds, poragens, and byproducts from divinylbenzene. Macroporous beads were, however, ideal for synthesis of large oligonucleotides in solid bed reactors. To synthesize small molecules it was best to use a polymer structure, which behaved like a sponge soaking up large quantities of solvents and monomers. This meant that cross-linkage had to be kept as low as possible to provide sufficient cohesion and mechanical strength for the beads to survive shear forces in the synthesizer. We described our gel-structured beads as a “solid drop” because in the swollen state they were like solvent droplets hold together with long chains of polystyrene.

After 1 year of fundamental research and development work, we started to manufacture the first Merrifield beads by copolymerizing chloromethyl styrene with styrene. Our clients insisted on getting beads with a chloromethyl group in para-position so as to obtain uniform kinetics. It was almost like starting anew. Nothing worked, and the beads were anything but round and uniform. The monomers were highly toxic, intensely colored, and available only as isomer mixtures. Our polymer chemist had to find suitable monomer manufacturers, and after that hurdle was taken we had a major problem with unwanted cross-linking reactions. In our despair we took a closer look at competitive materials and were surprised to find that they had an even bigger problem (see Figure 2).

By 1997 the target was reached: we had a perfect *p*-chloromethyl polystyrene bead with a loading of 1.9 mmol/g. Concurrently our organic synthesis chemist developed a “pulse purification” process using various types of solvents and a proprietary posttreatment reactor. This process removes any unwanted impurities from within the beads including oligomers and catalytic residues. After 2 years of research we had a very high-quality solid-phase material for combinatorial chemistry, but our collaboration with Novartis started to wane, since they began their own bead modification and linker development program. We were fortunate to be able to participate in a very exciting project within F. Hoffmann-La Roche.³⁷

By early 1998 we started to export the first beads to selected companies in the international market. At that time the combi-chem euphoria of earlier days had quieted down. Many chemists who started using solid-phase organic synthesis strategies moved back to traditional liquid-phase synthesis. They claimed that they did not have sufficient time

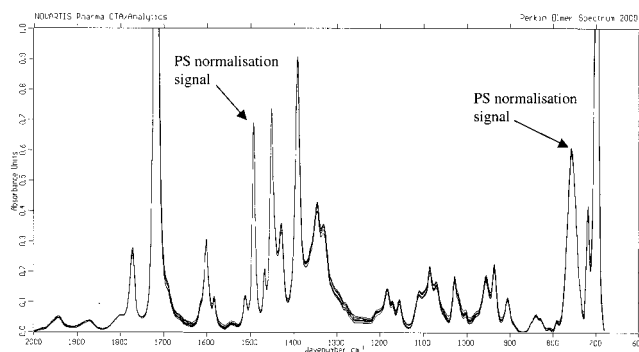

Figure 4. FTIR spectra of eight single beads, transmission mode. Functionalization of LCC-Dynospheres (phthalimide protected aminomethyl-polystyrene).

to learn this new technique. There was a shift in need from solid-phase synthesis materials toward resin-bound reagents, catalysts, or scavengers for use in liquid-phase reactions. It was interesting to observe that in some companies solid-phase chemistry was on its way to become a mainstream technique used by all chemists, while in other companies only a small group of specialists were using this technique. Many lead optimization chemists were cynical about the successes achieved in combinatorial chemistry. They complained about not getting enough sample materials and about poorly reproducible results. When we suggested that this situation could be improved dramatically when using precise solid-phase materials, such chemists looked at us in disbelief. Many argued that the high quality is important to single bead synthesis only. We accepted that not every application requires high-quality materials—particularly for scavenger resins. To offer such clients the best choice, we introduced LCC-Macrospheres made by a traditional suspension polymerization process, vis-à-vis the high-quality LCC-Dynospheres.

By late 1998 Peter Schneider informed us that he was invited to present his research results at The Third Lake Tahoe Symposium on Molecular Diversity, and I am happy to supply a short summary of his contribution:

Single bead FTIR and FT-Raman spectroscopy (in transmission and reflection mode from randomly selected beads) was used as the analytical tool to study on-bead the influence of reaction parameters on the loading, yield, and homogeneity of the reaction products.³⁸ Usually 6–20 beads are selected depending on the homogeneity. The spectra are normalized with the appropriate polystyrene signals allowing quantitative measurement, which nicely correlated with off-bead analytical measurements, such as HPLC, elemental analysis, or quantitative Fmoc determinations. With these beads and the appropriate analytical tools chemists are able to optimize solid-phase reactions almost with the same ease as in solution-phase chemistry.

Optimization of several reactions on the LCC-Dynospheres corroborates the anticipated properties of these new beads. An optimized aminomethylation method to functionalize the beads produces homogeneously loaded beads with very good swelling behavior and reproducible loading capacity (see Figure 4). From one bead approximately 5–8 nmol of compound can be cleaved depending on the chemical yields of the reaction sequence. The transformation of the ami-

Table 4. Swelling Behavior of Various Highly Loaded 250 μm LCC Beads, PS-C₆H₄-R^a

resin	R	mmol/g	dry	THF	DCM	DMF	DMSO	CH ₃ CN	MeOH	DCE	H ₂ O
1	H		1.4	8.9	8.4	5.0	3.0	2.3	1.5	7.2	
2	CH ₂ NH ₂	1.8	1.6	8.5	8.1	6.9	4.5	3.2	3.4	8.5	
3	CH ₂ Cl	1.5	1.9	9.4	9.0	7.5	5.4	3.3	2.3	7.8	
4	CH ₂ NHCH ₃	1.4	2.0	7.0	7.0	6.5	4.5	3.3	3.0	6.0	
5	4 + Rink linker	0.74	1.4	4.5	5.2	4.9	4.5	2.5	1.9	5.0	
			3.0	9.7	11.2	10.5	9.7	5.4	4.1	10.7^b	
6	4 + HMPA linker	1.05	2.0	6.7	6.3	6.6	6.0	2.9	2.9	5.5	
			2.5	8.3	7.8	8.2	7.5	3.6	3.6	6.8^b	
7	SO ₃ H	2.85	1.4	6.5	7.0	13.0	13.5	2.5	15.5	5.4	18.0
			1.8	8.7	9.3	17.4	18.0	3.3	20.7	7.2	24.0^b

^a Beads were washed with approximately 30 mL of solvent in the order outlined in the table (30 min for each solvent). ^b Bold values are normalized to equal number of beads.

nomethyl group to an isocyanate and its subsequent use as a scavenger for amines, as another example, also gave highly reproducible yields from bead to bead (90% \pm 3%). The unique polymer structure of LCC beads is further demonstrated by the low-temperature sulfonylation of LCC beads. Again, the FT-Raman spectra of individual beads was highly comparable (\pm 3%). Remarkably, these beads swell reversibly in water by a factor of 12 without any physical destruction (Table 4).

As mentioned, the copolymerization with pure *p*-chloromethyl styrene guarantees a reproducible loading and a uniform reaction kinetic. The chlorine of the chloromethyl substituent is easily exchanged with methylamine, and the subsequent derivatization of the methylaminomethyl group of LCC-Dynospheres with different linkers showed excellent reaction kinetics and reproducible batch-to-batch loading (94.5% \pm 3%). Beads analyzed with FTIR showed the same loading within the experimental error.

These results exemplify that LCC-Dynospheres are suitable for achieving highly reproducible loading, moreover allowing the optimization of chemical reactions on the basis of single bead analysis with the ability to project the micro result to all beads within the batch.

By early 1999 we at LCC started to assess successes in combinatorial chemistry. Our survey showed quite clearly that the expected explosion of new hits has not happened yet and that the initial idea of reducing research and development time is still a dream. What has happened is a shift in compound-to-hit ratio. A few years ago the ratio was roughly 100 000 new compounds to 1 hit. Today this ratio has changed to 400 000 new compounds to 1 hit. It is said that 11 hits are required for producing one new drug. This shift should not be a problem since there has also been a shift from manual to highly automated synthesis. In the real world, however, this equation does not add up, and one must ask why.

We were curious and extended our survey to natural product chemists. From those we learned that their compound-to-hit ratio is 2000 to 1—a figure almost incredible to believe. It was interesting to observe that natural product chemists were much more euphoric about their work than combinatorial chemists. Artuso³⁹ gives a more realistic estimate that 11 000 extracts will lead to a new drug. It is not uncommon to have 50–100 compounds in one extract. If this information is realistic, then we have to conclude that nature is much more efficient in making successful molecules than combi-

natorial chemists. What we did not find out with our survey were the costs of the two discovery processes. I do not have the precise words for it, but nature seems to producing more complex molecules, and because of that, I have to assume that the future of drug discovery lies in complexly structured small molecules. To build more complex molecules one needs protective groups. Solid-phase beads provide protection groups with additional benefits, and precise solid-phase materials are the best choice to manufacture complex molecules.

The business of LCC is to develop tools for chemists to improve the efficiency of drug discovery and manufacturing. At a recent conference,⁴⁰ it was interesting to learn that combinatorial technology companies were among the favored new subjects for venture capitalists. I tried to point out that solid-phase synthesis is an exciting technique not only for discovering but also for manufacturing complex molecules and that the quality of the solid-phase materials used will play a key factor in the success rate. To reduce research and development costs dramatically, we have to change the way new drugs are developed. The traditional path to a new drug consists of a chain, starting with the lead finders, the lead optimizers, process research, and process and pharmaceutical development. Large pharmaceutical companies employ highly dedicated groups of specialists with a high competency for a narrow technology segment. Parallel to those groups we have an expanding number of biotech companies, financed by venture capital who do similar, highly focused types of research in a narrow technology segment. The products or services developed by biotech companies have to go eventually through large pharmaceutical companies. In a way, biotech companies do compete with the technical specialists inside large pharmaceutical companies. We like to see both be successful in their pursuits, since there is enough space in the marketplace for new drugs. In the final analysis I believe the race will be won by those enterprises with lower research and development and production costs. The best strategy for doing that is to get the links in the chain closer together. Our contribution is in making available solid-phase materials which fulfill the needs of lead finding, lead optimization, process research, and process development chemistry. The answer to those needs is a product palette of solid-phase materials for use in solid-phase organic synthesis as resin-bound reagents, catalysts, or scavengers and which provide reproducible results and fast reactions and are stoichiometric, precise, competitively priced, and recyclable.

How will the pharmaceutical industry evolve? The global pharmaceutical industry is presently made up of 23–26 very large patent pharmaceutical manufacturers, many hundred generics and OTC pharmaceutical companies, and a rapidly expanding biotech industry. Most of the biotech companies have been financed by venture capital and investors who expect to get a good return on their investment. This hope will come true if the company produces a product/service which fits comfortably into the pipeline of large players. The United States has approximately 1400 biotech companies, with a similar effort in Europe. Large user markets, such as China and India, have been largely forgotten in this equation, but the governments in those countries strive to build an independent life science sector. It is highly unlikely that all of the growing supply of new product opportunities will or can be taken up by the relatively few remaining patent pharmaceutical companies. A more likely scenario is that new (virtual) patent pharmaceutical companies will emerge. It is to be hoped that venture capital funding will take on the role of large pharmaceutical companies and consolidate compatible biotech companies and generics suppliers into new patent pharmaceutical companies. The big winner in this consolidation process will be those who embrace technologies which tangibly shorten the product development cycle. This will benefit all those manufacturers who offer new analytical techniques and bioassays, companies who produce new intermediates and advanced separation/purification processes.

From customer inquiries, we are confident that precise solid-phase materials will be used as a platform for building new compounds or modifying known compounds, as supports for dangerous or unstable reagents, as catalysts or scavenger materials, as “hooks” to selectively fish out target compounds from a mixture of compounds, and as biosensors or microanalytical electrodes. For those concepts to work, highly defined and chemically pure beads are a must—in short use LCC-Dynospheres.

Composite and Pellicular Particles

D.H. comments: As Bruce Merrifield records in his Part I contribution, he produced the predecessor of such particles by grafting styrene onto a PS core. This fact remained unpublished, but the idea resurfaced in a collaboration between Geoff Tregear and ICI Australia, which produced beads consisting of a coat of linear polystyrene radiation-grafted onto a core of Kel-F, a highly chemically resistant fluorocarbon. These materials became quite well accepted and were used for a variety of peptides, but commercial supply was problematic. The idea, perhaps, was the seed for Mario Geysen’s adoption of the same grafting technique for producing acrylate films on the original “PepSets”. It resurfaced, in yet a different format, as PS-coated PE films, by Merrifield and Tam. Next IRORI picked up the baton with similarly coated MicroTubes (see Zhao’s contribution in a later section). A minor informal collaboration between IRORI and Biosearch Technologies applied the same chemistry to produce an economical particular composite with a high-density PE core (PE-PS). Many organic reactions can be performed with reasonable efficiency on all of these

variations. PE-PS itself is compatible with flow through systems, even though the coat does shrink or swell somewhat on solvent exchange. The magnitude of this effect is much less than with conventional “gel-type” beaded resins and is also dependent on the density of the polymer film. This is an important, but poorly understood, variable: the irradiation conditions have a major influence, both in the overall dose and the dose rate for which it is applied. One danger is that these materials may shed their “shell” of polymer during synthetic manipulations, although the nature of the grafting process makes this unlikely. The reader is referred to the resin comparison segment for a discussion of the merits of PE-PS and other polymer-coated PE particles recently produced, as well as to coated polymer MicroTubes. A variety of magnetic cored materials, especially nanoparticles, are useful for display of biomolecules but have not normally been used for synthesis. Particle handling without normal filtration procedures is possible with materials bearing paramagnetic cores, which have considerable potential.

Graft Copolymers

D.H. comments: This section deals almost exclusively with the production of PS-PEG graft copolymers. I am fortunate to have this topic thoroughly surrounded, so little comment is actually necessary, but, nevertheless, I cannot resist the temptation to add a few words concerning my own insights. There are two fundamental methods of preparing PS-PEG graft copolymers: (a) that which relies on anionic polymerization of ethylene oxide onto sites on the resin to generate, in situ, the graft resin (TentaGel, ArgoGel) or (b) methods which attach preformed PEG’s to the resin (PEG-PS, the Champions, NovaGel, DendroGel). The structures of several of these variants are given in Figure 5. In the late 1980s I had initiated, in ignorance of Merrifield’s pioneering work but mindful of Geoff Tregear’s nice pellicular material, a small program to develop coated resins, since new column compatible materials were much needed to fuel the Milligen/Biosearch 9050 and like flow through synthesizers. So when George Barany introduced me to the PEG-PS resin, which he and Fernando Albericio had developed, I was not motivated by promises of improved synthesis efficiency when I threw my development efforts into this project, but rather was attracted by the improved pressure stability and lower tendency to adhere to glass surfaces.⁴¹ Nevertheless, my early resin comparison studies (done at this time) showed distinct improvements in product purity compared to the standard PS we were then using.

More recently, at Biosearch Technologies, I developed a family of related PEG graft resins, NovaGel, Champion I and II, and DendroGel.⁴² Their properties are quite fully described in the quoted literature and are also discussed in the last section. A visual corroboration of their excellent swelling characteristics⁴³ is provided in Figure 6, which shows an optical microscope image of some NovaGel beads, suspended in DMF; their clarity, best judged where they overlap, is quite remarkable. An important point that is worth underscoring is that our comparison studies showed little difference between the performance of these new copolymers to PS (when this had been prepared by an improved

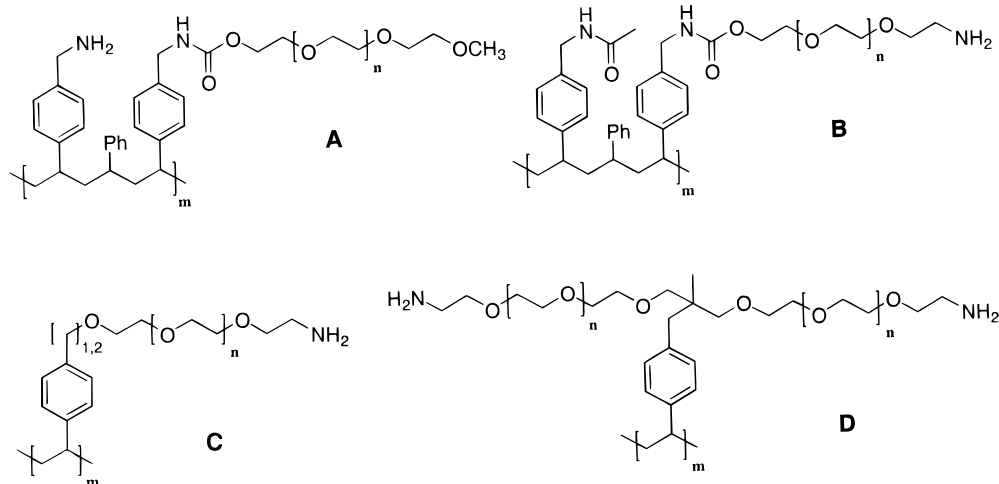

Figure 5. Structures of a variety of commercially available PS-PEG resins: (A) Champion I, NovaGel; (B) Champion II; (C) TentaGel (original formulation CH_2 PEG attachment, current TentaGel S formulation CH_2CH_2 attachment); (d) ArgoGel. All resins are shown in amino-functionalized forms.

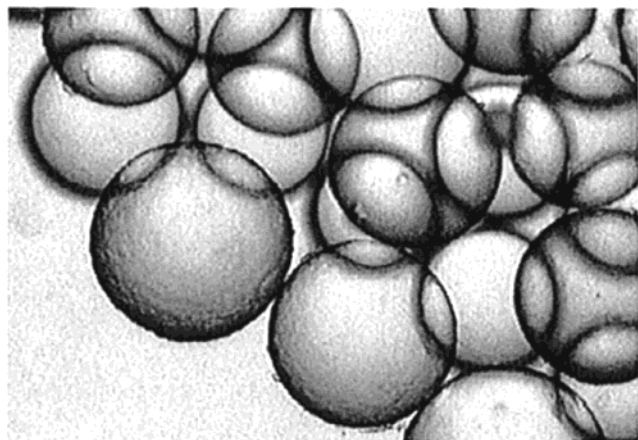

Figure 6. Photograph of optical microscope image of Rink linker derivatized NovaGel resin beads swollen in DMF (photo courtesy of Biosearch Technologies, Inc.).

procedure and comparably loaded) and that of alternatively formulated PS-PEG's. There was, consequently, no evidence for a spacer arm effect. Minor differences were observed, such as clumping of ArgoGel in a stilbene formation reaction series and PEG loss from TentaGel during TFA treatment. Much as I would like to portray the development of these resins as a rational process, I was particularly taken with the excellent swelling of DendroGel (not to mention a feeling of pride associated with bringing forth yet another attention grabbing name). It had been developed considerably earlier than its kin and proved to be a work horse in the production of numerous peptide-DNA hybrids (prepared for evaluation under one of our SBIR grants). Its synthesis, though, was time-consuming and, therefore, expensive, so I conceived of simpler alternatives, the Champion series, and subjected them to a battery of comparisons. I was extremely surprised to find the more complex multibranching DendroGel performed no better than its less sophisticated cousins or other commercial alternatives.⁴⁴ There are many merits to the simplicity of the Champion I/NovaGel formulation; this confers the desirable properties of high loading, stable attachment, and excellent solvent compatibility.

It has taken the excellent work of Mark Bradley to develop the "ultimate" expression of solid-phase dendrimers, a topic which he has reviewed in depth recently.⁴⁵ The arena is now open for the protagonists of other variations to tell their stories; as with most things I have been associated with, the relative merits of these variations on a theme have not been without controversy!

George Barany.⁴⁶ Poly(ethylene glycol)-Containing Supports for MAST

It is with a tip of the baseball cap to Derek Hudson, a long-time on-and-off collaborator and always a PAL,⁴⁷ for his enthusiasm and perseverance, that I turn from the labors of Peptide Symposium administration⁴⁸ to reminisce about how, through several serendipitous turns of events, my laboratory and those of some of our academic and commercial collaborators had the good fortune to be involved in the development and widespread acceptance of two of the most promising and arguably useful families of supports for solid-phase synthesis. Our work on poly(ethylene glycol)-polystyrene (PEG-PS;⁴⁹ see Figure 7) graft and cross-linked ethoxylate acrylate resin (CLEAR;⁵⁰ see Figure 8), both of which contain a hydrophilic poly(ethylene glycol) component, has been reported and reviewed in several formats, and the reader who seeks scientifically rigorous accounts and the attendant documentation is referred to those writings.⁵¹

Derek has encouraged contributors to write in the first person and relate things that might not pass muster in the prim refereed literature. Most of our successes can be attributed to the intellectual and experimental accomplishments of several dedicated (and sometimes stubborn) individuals whose names will be mentioned as this narrative unfolds; my own scientific background lacks many of the specific tools that are commanded by the majority of those who have moved forward the field of solid supports for synthesis. In addition, it should be noted that overlapping the fertile period when our discoveries were made and ultimately commercialized, my main professional agenda was to establish myself as an independent investigator and work my way up the ranks at the University of Minnesota.

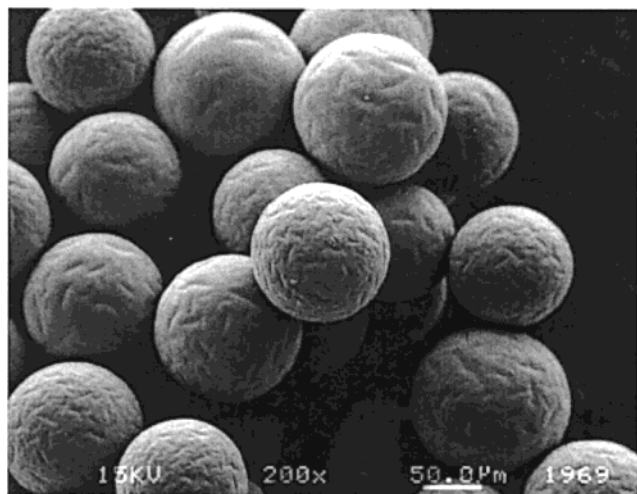

Figure 7. Scanning electron micrograph (SEM) of PEG-PS beads (photo courtesy of PerSeptive Biosystems).

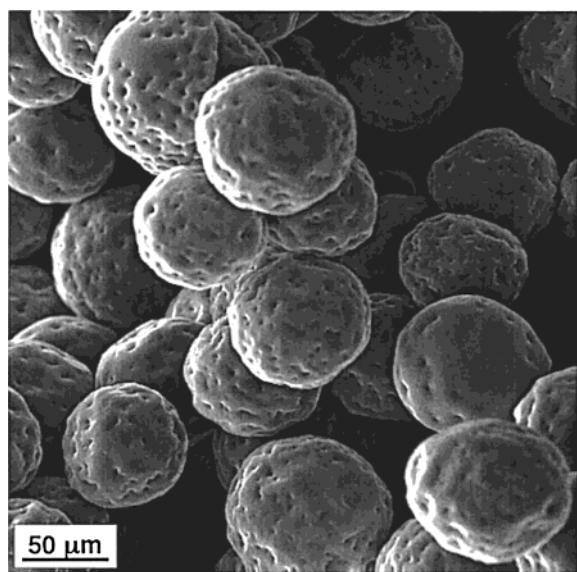

Figure 8. SEM of a group of CLEAR resin beads (photo courtesy of Peptides International).

Naturally, memories can be both defective and selective, and time heals most wounds, so I hope that my comments are uplifting and apologize for any inaccuracies or exaggerations.

As a graduate student and postdoctoral fellow during the 1970s in Bruce Merrifield's laboratory at The Rockefeller University, I proposed the thiolizable dithiasuccinoyl (Dts) amino protecting group⁵² as the basis for an orthogonal⁵³ alternative to the graduated acid lability "fine-tuned" Boc/Bzl schemes that at the time represented the only viable way to efficiently synthesize peptides. Our initial experiments with Dts provided the test tetrapeptide Leu-Ala-Gly-Val in about 97% purity, hardly awe-inspiring but nevertheless a good beginning. The base-labile Fmoc group came along more or less simultaneously, first as an exercise in pure organic chemistry from Louis Carpino's group at the University of Massachusetts—Amherst and then for peptide applications in magnificent independent programs headed by Eric Atherton and R. C. Sheppard at the Medical Research Council in Cambridge, England, and by Hans Meienhofer's team at Hoffmann-La Roche in Nutley, NJ. Of course, we now know that Fmoc chemistry⁵⁴ (particularly with supports other than

the conventional polystyrene, as covered both in my own remarks and elsewhere in this two-part opus) is equal to just about any challenge in peptide synthesis, including fragile targets such as phospho-, sulfo-, and glycopeptides, but the situation was not nearly as clear at that time. Thus, it was with Bruce Merrifield's blessing that I applied for academic positions with the ambitious goal to overhaul protection strategies for peptide synthesis and extend a methodology rising out of Dts to the routine preparation of labile proteins. I turned down the opportunity to inherit the well-equipped laboratories of one of my idols,⁵⁵ Professor Miklos Bodanszky at the Case Western Reserve University in Cleveland, and opted to accept for the fall of 1980 a startup package that was absolutely miserly by today's standards and to inhabit empty⁵⁶ laboratories in the frigid Northwest. Fairly soon after I began at Minnesota, the internally inconsistent advice that I was getting from leaders in various arenas was to (a) get Dts to work, the sooner the better, and (b) initiate and complete an entirely unrelated body of chemistry that could be associated with my name and not with my Rockefeller heritage.

Two key people who believed in Dts enough to be willing to try it at the laboratory bench were Fernando Albericio from the University of Barcelona, the first postdoctoral fellow to sign on although the third to arrive (his tenure in Minnesota was from 1983 to 1984; however, see ref 57), and Derek Hudson himself, who called me out of the blue in 1985 from his position with a small West Coast company called Biosearch and offered me my first-ever consultantship in return for first crack at commercializing the methodology. Meanwhile, Shmuel (since Americanized to Samuel) Zalipsky, an ambitious graduate student who came to Minnesota with a master's degree from Chaim Gilon's lab in Jerusalem, elected to carry out his doctoral studies with me. Zalipsky was asked to solve a practical and very important problem related to the reasonable-scale preparation of *pure* Dts-amino acids, by an approach that played directly into his extensive experience with the derivatization and utilization of PEG. In a nutshell, PEG was required as a carrier to remove a class of low-level impurities that we expected to be present due to an unavoidable side reaction to the heterocyclization step in Dts creation. Shmuel was able to quickly show that my idea would work, including to figure out the optimal molecular weight and functionality of the PEG (i.e., bifunctional with average molecular weight 2000, the highest capacity and smallest size to allow ready "crystallization" of the PEG intermediates). I assigned an eager, inexperienced but socially mature undergraduate, Adele Binning, to assist Shmuel with the tedious process of cranking out more examples (and by so doing, to indicate my strong support and enthusiasm for the project). Shmuel and I were constantly arguing about whether experiments to prove mechanisms were even needed, and there was one particular control that he was so reluctant to do that finally I just asked Adele to give it a try. The result was unexpected and extraordinary (one of the coproducts was a trisulfide that we just happened to have in the lab from the organosulfur studies that some sympathetic and well-intentioned experts thought were a waste of our time), and the next day every blackboard in

the chemistry buildings had in Shmuel's elegant handwriting the explanation of what had really happened. Shmuel continued the mechanistic studies by showing that neutral and charged PEG's could be separated by ion-exchange chromatography on Sephadex and then, completely unbeknownst to me, proceeded to generalize what he had learned to make, in six chemical steps and one key chromatography step: a Boc-protected heterobifunctional amino acid PEG.

On the other side of the laboratory, Fernando Albericio was getting more and more frustrated, although to his everlasting credit not throwing in the towel, in his experiments to use the Dts-amino acids generated by Shmuel and Adele for the synthesis of real peptides, both free and protected.⁵⁷ He was also scouting out new research territory, and he knew from his friends in the DNA synthesis arena that some kind of long "spacer" attached to controlled pore glass (CPG) beads could be very useful. Fernando and Shmuel agreed to work together to link the heterobifunctional PEG to CPG, but the incorporations and loadings were so low that they abandoned this line of investigation. However, in the process of trouble-shooting why the putative PEG-CPG material was so difficult to come by, they were able to successfully attach the PEG to low cross-linked polystyrene (PS). The coupling resulted in a doubling the weight of the original support material, and that was how "first-generation" PEG-PS graft resins first came to be.

Our initial report on the subject was presented in June 1985 as a poster at the Ninth American Peptide Symposium in Toronto, and we modestly claimed that PEG-PS offered subtle but reproducible advantages over PS with regard to physicochemical properties (e.g., good to excellent swelling in a greatly expanded range of solvents) and results of parallel model peptide syntheses. Granted, the peptide was an easy one, the Merrifield tetrapeptide Leu-Ala-Gly-Val already alluded to, and in Albericio's hands in a Dts synthesis, the purity was 98.8% on PS versus 99.6% on PEG-PS. Also, the acidolytic cleavage yields under matched, minimalist conditions were 54% for PS versus 74% for PEG-PS. In Zalipsky's hands, as reported in his Ph.D. thesis (1987), PS was again outperformed by PEG-PS in the Dts (97.7% vs 98.8%) system, while numbers were comparable (98.9%, 98.7%) with Fmoc. We were careful to not overinterpret these data; after all, Shmuel's best PEG-PS values were not as impressive as Fernando's worst PS values. But for a while, we thought that things might be even more spectacular, with respect to the well-known and notorious Ile to Asn coupling that occurs early in the synthesis of Garland Marshall's acyl carrier protein (ACP) decapeptide. An ingenious competition experiment was designed, which was modified by Hudson to compare coupling conditions and supports.⁵⁸ For our situation, though, my caution and insistence on reproducing work served me in good stead, even though it delayed publication of the definitive first full paper by more years than I would have liked.^{49c}

As Fernando and Shmuel left for other vistas, my Minneapolis laboratory floundered in terms of establishing the original vision for Dts in its full generality⁵² but forged ahead with Fmoc peptide synthesis. Our focus shifted to the development of numerous handles, e.g., PAL, and the

pioneering of on-resin cyclization methods—in particular to create intramolecular disulfide bridges—while work on PEG-PS was put on a back burner. Moreover, we were pessimistic that the lengthy, time-consuming, and labor-intensive route developed by Shmuel could ever be scaled up and become commercially viable. The one bit of encouragement for PEG-PS during the late 1980s was the enigmatic and ill-defined assertion by Derek that some material he had received from Shmuel showed less "clumping" in the Biosearch synthesizers than did PS, but for a while, there was no follow-through. All this changed in 1989 with the arrival in my laboratory of a University of Illinois—Urbana classically trained organic chemist, Jane L. Chang. Over a highly productive 18 month tenure, Jane revisited the PEG-PS system, both as made by the original Zalipsky method and by an ingenious "second-generation" route that was far more compact (see below). Just as importantly, Jane carried out the first experiments that convinced me of the special properties of PEG-PS: One was an oxytocin synthesis with on-resin disulfide cyclization which worked out better than a parallel experiment carried out on PS, and the second was to synthesize the full-length ACP decapeptide using acetonitrile as a solvent for all coupling and wash steps—the synthesis worked marvelously on PEG-PS whereas amino acids were not even incorporated when the same protocols were conducted on PS!

These results in Minneapolis were shared with Derek, and our collaboration cranked up with added vigor, aimed at the optimization and validation of PEG-PS as a product. As an important piece of the puzzle, Biosearch had merged with MilliGen, an East Coast company with its flagship synthesizer the Model 9050. The MilliGen instrument featured a continuous-flow mode for circulating reagents and solvents and washing, in contrast to the Biosearch instrument with which synthesis was batchwise and gentle agitation was achieved via positive nitrogen pressure. The exciting finding was that PEG-PS performed well with both instruments, and this was particularly significant because use of PS on continuous-flow was contraindicated due to the high backpressures and physical fracturing of beads thus encountered. On the preparative chemistry side, we had realized that PEG-PS could be made by coupling homobifunctional PEG derivatives to PS, conceding that some cross-linking would occur but noting that there would still be an adequate substitution level for the materials to be useful for synthesis. In Jane Chang's work, inexpensive and commercially available PEG-diamines were treated with maleic anhydride, creating carboxyl groups for coupling to amino-derivatized PS and allowing later selective hydrolysis of maleoyl groups to regenerate amino sites on the resultant PEG-PS. At West Coast MilliGen/Biosearch, Derek, working with Dean Tsou and Matthew Lyttle, scaled up the procedure and made iterative improvements, ultimately using succinic anhydride in place of maleic anhydride and establishing the required amino groups by coupling ethylenediamine. We worked feverishly to file a patent application on August 31, 1990 (last minute revisions were dictated from a hotel room in Washington, D.C.), and jetted across the Atlantic to the 21st European Peptide Symposium in Platja d'Aro, Spain. At an extraordinarily well-attended evening satellite session spon-

sored by MilliGen/Biosearch and chaired by Fernando, both Derek and I lectured. Derek got some laughs with a cartoon slide (drawn by Gordon Cockroft; the original art hangs framed in my office) of him and me (wearing a Mets cap) playing golf and scoring a ball labeled "PEG-PS." While it was sobering to listen to some of the critical and skeptical comments from a handful of the distinguished peptide scientists in the audience, overall, I recall the evening as one of considerable euphoria.

One major twist in the PEG-PS story was yet to be played out, even as the cast of characters shifted (Derek turned down a generous relocation offer when MilliGen/Biosearch decided to consolidate on the East Coast, Steven A. Kates joined the team in 1991, Bill Griffin was a key player in Boston, and for a while, Fernando also worked in Boston; meanwhile Nuria A. Solé was with my team in Minneapolis from 1990 to 1993). Recall that our working assumption in developing PEG-PS was that its efficacious properties stemmed from PEG serving as a "spacer". When our chemical analyses and calculations revealed certain batches of PEG-PS that worked well for peptide synthesis but did not have a sufficient number of PEG chains with free endgroups to account for the overall loading, I was forced to consider the possibility that "environmental" effects might be of equal or greater importance. The idea was proven with Nuria's formulation of a PEG-PS with an ornithine branch point and capped PEG chains. A natural evolution of this theme was the development of various "high-load" PEG-PS resins together with Steve, Fernando, and Brian McGuinness. A further advance was the reformulation of PEG-PS to be entirely stable to strong acids such as anhydrous hydrogen fluoride (HF), and it was only a matter of time before the superiority of PEG-PS for combinatorial chemistry became obvious.

After Derek's 1990 EPS lecture already mentioned, I would like to think that two other lectures, that I myself gave in 1991, influenced the gradual acceptance of PEG-PS. The first was at Roger Epton's Second International Symposium on Innovation and Perspectives in Solid Phase Synthesis and Related Technologies in Canterbury, England, in the summer, and the second was as part of the Carlsberg Research Laboratory "Frontiers in Science" lecture series in Copenhagen, Denmark, in the fall. At the Canterbury meeting, I clearly explained the environmental effect and also emphasized how our PEG-PS approach using defined PEG building blocks differed from that of Wolfgang Rapp⁵⁹ and Ernest Bayer who were polymerizing ethylene oxide directly onto specially prepared uniform functionalized PS beads. The highlight of my Copenhagen trip was Morten Meldal's gracious hospitality,⁶⁰ and our discussions may have helped him with his thinking that led to the excellent PEG-A family of supports described in Part I of this opus.

The introduction to this essay defined the CLEAR family of supports which I view as complementary to PEG-PS. The successes here are a testament to the tremendous skill and tenacity of Maria Kempe, who trained in Klaus Mosbach's molecular imprinting laboratory in Lund, Sweden, and spent two years (1994–1996) in Minneapolis as a Hans Werthén postdoctoral fellow. Maria is now an independent investigator in Sweden continuing studies on CLEAR and allied topics,

and within the past few years, Arno Spatola's company Peptides International in Louisville, KY, has launched a CLEAR product line which is growing nicely. Having hung my hat on the idea that an academic enterprise involved in support development should start with preformed polymers that could be derivatized and combined, I was surprised to learn that Maria proposed to not only carry out polymerizations in my laboratory but even work out the tricks to obtain uniform, beautifully spherically beaded material (this latter accomplished starting from ground zero in less than a month, under the pressure of revising a manuscript for *J. Am. Chem. Soc.*). CLEAR supports swell in a wide range of solvents and have good mechanical stability, but what is so counter-intuitive is that these properties are achieved by material that has a very high weight ratio of a trifunctional cross-linker. Kempe carried out the same kinds of studies that we had used to validate PEG-PS, including batchwise and continuous-flow examples and the synthesis of the ACP decapeptide under regular and acetonitrile as solvent conditions, and the results were uniformly impressive as described in our *J. Am. Chem. Soc.* publication.⁵⁰

Where do we go from here, and what have we learned? The creation of useful materials for synthesis, be it peptides, oligonucleotides, or small organic molecules for combinatorial chemistry applications, requires equal measures of luck, intuition, and fortitude. One must be ready for surprises and willing to adapt one's approaches. A current and new direction of our research, in collaboration with my brother Francis, can be summarized with the slogan "transform PEG-PS and/or CLEAR onto surfaces." To date, we have a surface version of polyacrylamide gels, as a three-dimensional matrix that supports (double meaning) DNA hybridizations as a basis for array testing of mutations.⁶¹

Wolfgang Rapp.⁶² The Development of TentaGel Resins

I started in 1981 with solid-phase organic synthesis mainly focused on the polymer support and its applications. At that time only a few solid supports were used in peptide and oligonucleotide chemistry, such as the cross-linked polystyrenes introduced by Merrifield, polydimethylacrylamide resins introduced by Sheppard and Atherton, and CPG or glass. Solid-phase synthesis suffers from diminished kinetic rates compared to those in solution but can easily be automated, whereas liquid-phase chemistry poses considerable problems in automation. Our goal was to combine the advantages of both techniques to create a system where we can do solid-phase synthesis under liquid-phase conditions.

The most desirable way was to introduce PEG onto a polystyrene matrix. We knew, from previous internal investigations, that introducing preformed PEG via Williamson ether synthesis to chloromethylated polystyrene would not work because of the low conversion rate, the presence of unreacted chloromethyl groups, the lack of reproducibility, the generation of additional cross-linking, and the low capacity of the resulting resin. The first successful synthesis of the polystyrene poly(ethylene glycol) graft copolymer was finished by the end of 1981. This first generation of graft copolymers consisted of a 1% cross-linked PS matrix with

the PEG chain attached to the polystyrene matrix by a benzyl ether linkage. In contrast to previous synthesis routes, we built up the PEG spacer directly on the polystyrene matrix by an anionic graft copolymerization process with ethylene oxide. This process prevents any additional uncontrolled cross-linking. The resin shows excellent chemical properties with respect to swelling and stability. Due to the grafted PEG moiety, the physicochemical properties of the products are dominated by the PEG spacers. The resin swells in aqueous systems as well as in organic solvents. The reactive sites are attached at the end of the PEG tentacles and behave kinetically like in solution. This new system combines the advantage of solid-phase and liquid-phase chemistry and allows solid-phase synthesis to be performed under liquid-phase conditions. This first generation of PEG-grafted polystyrene resin was mainly used in solid-phase peptide synthesis and oligonucleotide synthesis. As the resin shows excellent pressure resistance, it was used, at that time, in newly developed flow through peptide synthesizers. In 1989 the resin was commercialized under the trademark TentaGel resin.⁶³ Very soon we recognized that the benzyl ether linkage between the polystyrene matrix and the PEG spacer was not completely stable to TFA treatment or to harsher acid conditions used for acid cleavage, and side chain deprotection, in Fmoc peptide synthesis. We, therefore, introduced in 1992 a second generation of TentaGel resins with improved acid stability. To overcome the acid sensitivity of the benzyl ether function and to prevent PEG leaching during acid treatment, now the PEG spacer was attached to the new TentaGel S resins by an ethyl functionality.⁶⁴

During the 1980s resins possessed a very broad size distribution, and almost no attention was paid to a more narrow particle size distribution. Because of the heterogeneous nature of the reaction in solid-phase chemistry, resin parameters such as polarity, particle size and solvation, mass transport, and diffusion are of prime importance in all polymer-supported reactions.⁶⁵ The driving force for mass transport is diffusion, which is dependent on path length. All solid supports which have normally been used in solid-phase chemistry show a more or less broad particle size distribution. Particle sizes of polystyrene, polyacrylamide, and TentaGel resins were mainly at that time in the range of 37–75 μm or 75–150 μm or even broader; kieselguhr/polyamide and Polyhipe were in the range of 500–1000 μm . Mass transport and reaction rates are individual parameters for each particle, whereas the overall reaction time is controlled by the size of the largest bead. To overcome these problems we started, in 1986, a program to develop small monosized tentacle beads for application in synthesis.

The monosized nature of these beads divides the total reaction space (represented by all beads) into identical small reaction compartments of equal size. The monosized nature and the uniform architecture allow optimization of the reaction conditions to a greater extent because of the identical reaction conditions for each individual bead. In 1991 we published the use of such monosized TentaGel beads for high-speed peptide synthesis. The synthesis time for β -endorphin was reduced from 16 h on 90 μm beads to 5 h using 15 μm beads.⁶⁶ Detailed investigations by HPLC and MS

have confirmed the theory that uniform reaction space represented by the beads yields purer products.⁶⁷

Different requirements for resins were needed with the development of the new library synthesis techniques. On the basis of the “split/mix technique” for generating libraries originally introduced by Furka and further developed by Lam, a number of peptide libraries have been synthesized and screened on TentaGel beads of various particle sizes. To achieve molecular diversity on solid supports either by combinatorial chemistry methods or synthesis of peptide libraries requires resins that are compatible to a broad range of organic reaction conditions and various solvent systems. Aqueous buffer systems are used for resin-bound biological assays and screening.

Nevertheless, many applications suffer from the restricted amount of substance which is available from one single bead. Several attempts were made to overcome this disadvantage, e.g., by increasing the degree of substitution on the bead or by lysine branching. Both attempts suffered from extremely slow reaction rates, incomplete reactions, intermolecular interactions within one bead, and slow release from the support.

Our idea was, therefore, to increase the amount of substance per bead by *increasing the particle size* (increasing the reaction space) but *not the concentration* of substance within the bead. On the basis of polystyrene or polystyrene-poly(ethylene glycol) graft copolymers (TentaGel) we introduced in 1994 macrobeads having particle sizes between 300 and 700 μm but having a narrow size distribution.⁶⁸ This increase of particle size raises the capacity/bead by a factor of 100–1000 into the nanomolar range, whereas the beads used so far have 50–200 pmol capacity. Each individual bead can be characterized by measuring its size and capacity. Dependent on particle sizes, capacities of 10–100 nmol/bead have been detected by quantitative Fmoc determination from single macrobeads. Further improvements were made by introducing up to three orthogonal protected functionalities on one bead for sequential cleavage.

Another very exciting aspect in organic solid-phase chemistry is miniaturization and automation. The described macrobeads can be used as polymeric microreactors in organic synthesis, where each bead represents an individual reaction space. We have used single beads of 300 μm in capillaries to synthesize one compound on one bead. For this technique, where each bead is addressed by a capillary, no tagging is necessary.⁶⁹ The synthesized compounds can be analyzed by ATR IR spectroscopy or by ¹³C and ¹H NMR spectroscopy on each individual bead in their synthesis environment which creates relevant data for reaction screening and optimization.⁷⁰

As solid-phase chemistry is still a very dynamic and exciting technique I am very sure that in the future new ideas and new developments will be made in resin synthesis and resin handling.

**Owen Gooding, Jeff Labadie, and John Porco.⁷¹
ArgoGel Resins: Poly(styrene–oxyethylene) Graft
Copolymer Supports**

In early 1995 we began a program to develop new and enabling resins that included a critical examination of existing

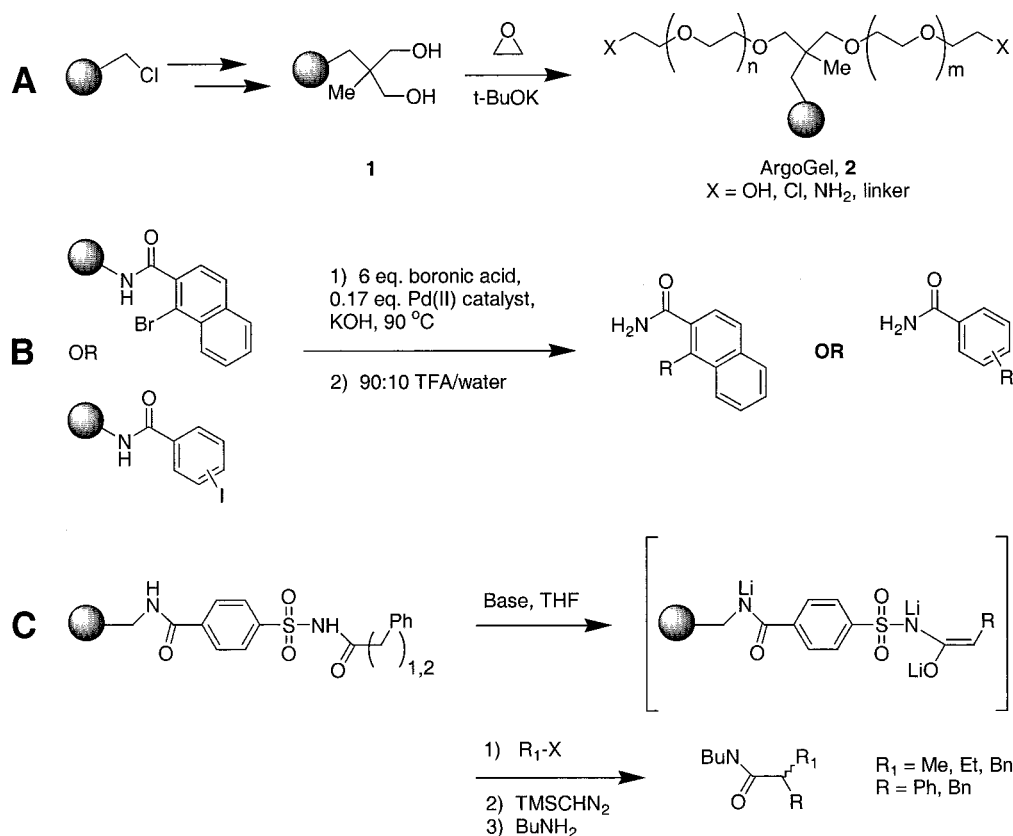

Figure 9. Schematic representations of (A) Preparation of ArgoGel; (B) Suzuki coupling chemistry; (C) enolate alkylation examples.

supports. We consulted a large number of pioneers in the area of combinatorial chemistry, including a Product Development Consortium⁷² assembled during development of the Nautilus 2400 synthesizer. At the time, many scientists using poly(styrene–oxyethylene) supports expressed concerns about the relatively low loading, the propensity to complex Lewis acids and leach linear PEG, and the relatively high cost due to the paucity of suppliers. As a first project we elected to investigate these supports and how they could be modified and improved.

Poly(styrene–oxyethylene) graft copolymers (PS-PEG), first reported by Bayer and Rapp,⁷³ had been commercially available for several years.^{74,75} These PS-PEG beads displayed relatively uniform swelling in a variety of solvents from medium to high polarity ranging from toluene to water and excellent reaction kinetics in peptide synthesis.⁷⁶ The polymers were produced by grafting ethylene oxide from the polystyrene backbone, creating long flexible chains that terminate with a reactive site spatially separated from the more rigid polystyrene backbone. The leading commercial product, TentaGel (see Figure 5C), was reported⁷⁷ to have the PEG graft linked to the polystyrene via a benzylic ether, a bond well known to be unstable to strongly acidic reagents.⁷⁸ The average graft length of 68 units (3000 D) afforded a PEG composition of ~75 wt % and a loading of 0.2–0.3 mmol/g.⁷⁹

Our approach to novel PS-PEG graft copolymers centered around improving the acid stability of the polystyrene graft linkage and increasing the functional group loading per unit weight of resin (mmol functional group/g resin). We envisioned improved stability could be obtained by replacing

the benzylic ether linkage with an aliphatic linkage and increased loading through bifurcation prior to ethylene oxide grafting. In effect, ethylene oxide grafting to a bifurcated intermediate affords a bifunctional PEG chain that is attached to the PS backbone at its center. This approach allowed the preparation of ArgoGel, new PS-PEG graft copolymers with twice the loading capacity relative to conventional monofunctional PS-PEG graft copolymers, while maintaining equivalent PEG molecular weights. The complete experimental details of this work were recently published.⁸⁰

In brief, a 1,3-diol-functionalized polystyrene intermediate **1** was prepared as shown in Figure 9A. Graft copolymers were then prepared by anionic polymerization of ethylene oxide initiated by the alkoxide formed from **1**. Deprotonation of the diol with excess potassium *tert*-butoxide followed by addition of a prescribed amount of ethylene oxide solution in THF led to facile polymerization as determined by weight gain of the isolated polymers (**2**, R = OH), FTIR, and ¹³C NMR spectroscopy. Graft lengths (*n* and *m*) were varied from 29 to 58 repeat units (67–82 wt % PEG) and the solid-state properties (crystallinity) characterized by differential scanning calorimetry. The optimum graft copolymer composition, determined by balancing the degree of functional group loading with resin crystallinity and swelling, was found to be in the 0.4 to 0.5 mmol g⁻¹ range. The hydroxyl substituted copolymer, ArgoGel-OH (AG-OH), was further elaborated to the chloro (AG-Cl) and amino (AG-NH₂) substituted base resins and ultimately on to seven linker substituted materials which are now available commercially.

Because the presence of residual linear PEG impurities was a major concern from the outset, a protocol for

measuring the levels by extraction with TFA/water (95:5) was developed.⁸¹ AG-OH and AG-NH₂ displayed excellent chemical stability to the strong acid cleavage conditions often employed in SPOS (TFA cleavage). The level of linear PEG (produced as a byproduct during grafting) was measured by extraction with 95:5 TFA/water for 4 h followed by concentration of the filtrate. Linear PEG levels of <0.5 wt % were routinely obtained.⁸² The resins also displayed good swelling in a panel of solvents ranging from toluene to water. Thus, PS-PEG supports are an attractive choice for syntheses where polar solvents are required.

PS-PEG supports are also particularly well suited for on-bead analysis via NMR. The relatively mobile environment created by grafting PEG chains on to the more rigid PS backbone facilitates the application of gel-phase ¹³C NMR in a standard spectrometer.⁸³ The advent of the magic angle spinning technology also allows high-quality ¹H NMR data to be collected; however, specialized equipment is required.⁸⁴ A recent paper describes the use of ¹³C NMR to monitor an ether formation on ArgoGel-Wang-Cl.⁸⁵

The ArgoGel family of supports has been available commercially since early 1996. Reports have appeared describing their use in the preparation of substituted imidazoles,⁸⁶ *N*-alkyl sulfonamides,⁸⁷ acylamines,⁸⁸ 4-arylazetidino-2-ones,⁸⁹ aminothiazoles,⁹⁰ and benzofurans.⁹¹ Water compatibility also allows on-bead screening assays to be conducted in some cases. ArgoGel supports contain very low levels of leachable linear PEG impurities and usually provide very clean products upon cleavage. They are particularly well suited for chemistry development where NMR can be used or for reactions conducted in polar solvents or water.

Rigid Macroporous Supports

D.H. comments: Led by the pioneering work of Letsinger, DNA chemists were quick to realize the merits of rigid solvent and reagent tolerant materials. In the early 1980s HPLC silicas were the choice (but required HPLC pumping systems to maintain flow).⁹² The discovery, by Adams,⁹³ that controlled pore glass performed even better and could be used in simple systems where reagents were fed by gas pressurization was a revolution. CPG, too, because of its combination of biocompatibility and chemical stability, has virtues for combinatorial chemistry. The first example that I know is provided by Barry Morgan, a friend and former colleague from George Kenner's group in Liverpool, who made excellent use of the properties of this selection in enzyme substrate libraries, which he playfully referred to as "peptides on the beach".

Of alternatives for DNA synthesis, macroporous PS (Andrus) and methacrylates⁹⁴ have proved comparable in performance, if not economy, and are additionally advantageous in that they are more stable to concentrated aqueous ammonia. Like CPG, polymethacrylate materials have been somewhat overlooked in the search for alternative materials for combinatorial chemistry, despite the fact that excellent results have been obtained both in DNA and peptide synthesis. The application by Joe Buettner, the development of novel affinity matrixes for protein purification via the intermediary of a library screen performed on the very same

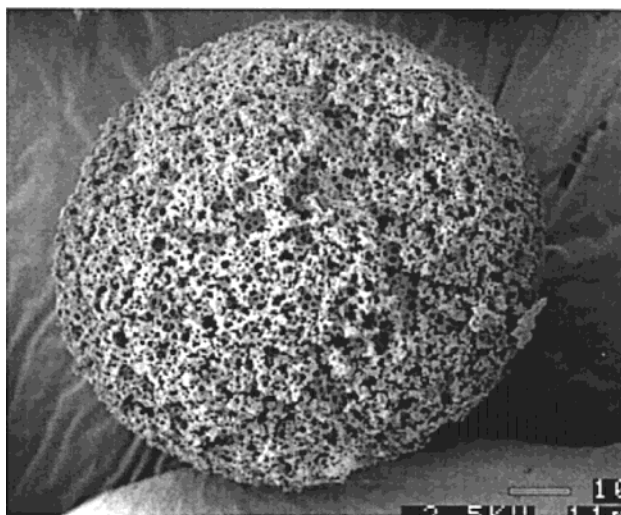

Figure 10. SEM of MagnaPore Bead (photo supplied courtesy of Bruce Morra and BioPore Corp., Mountainview, CA.)

material used for the affinity matrix is, in my opinion, perhaps the nicest example of the usefulness of bead-based libraries that exists. I was very happy to have the opportunity to help with some chemistry and support issues that arose.

Macroporous PS has gained rapid acceptance as a support for combinatorial synthesis; ArgoPore, described in the section by Gooding, Porco, and Labadie, is perhaps the most popular commercially available form. A recent development, which fits best into this category, is the development (by BioPore, of Mountain View, CA) of spherical beaded versions of the irregular polyHIPE, described by Sheppard and Sherrington in Part I. This inverse polymerization process gives rise to (Figure 10) totally porous PS materials, MagnaPore, penetrated by megapores. These products have numerous applications and offer minimal resistance in flow through applications; their performance in MAST is currently being evaluated at Biosearch Technologies.

Derek Hudson. ASPECT, A Novel Porous PE

I cannot resist adding to this category another minor contribution of my own. It provides a nice example of how an idea can mutate from its conception and how changing circumstances can affect the direction. Biosearch Technologies has been fortunate to obtain significant support under the SBIR program of the NIH. One of the grant applications was originally targeted at uses of plasma aminated membranes, a process developed by Beckman for DNA synthesis.⁹⁵ Since comparison methodology is deeply rooted in the way I tackle any project, I chose to compare the loading and synthesis efficiency of membranes functionalized in solution chemically and by RF plasma amination processes. Similar results were obtained. However, when the same processes were applied to powdered materials, vastly different results were obtained. The oxidative chemical processing that was fortuitously devised could derivatize 90 μ m PE particles to a level of over 100 μ mol/g and, when loaded at conventional substitution levels, gave quite high-quality DNA synthesis. The exothermic processing involved, apparently, softens the particles significantly, and the gas evolved generated porous channels (as determined by BET analysis).

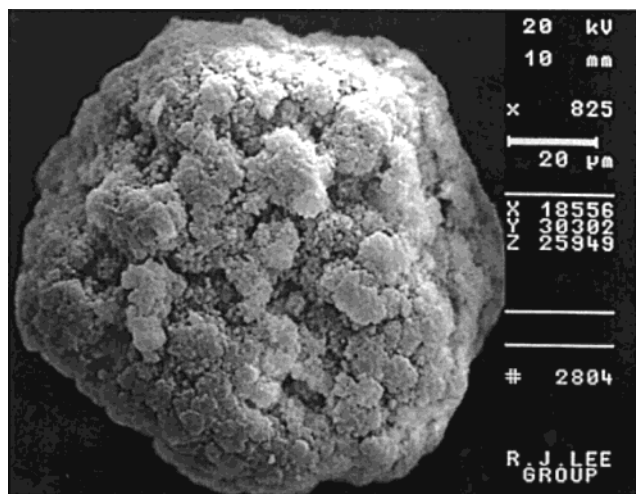

Figure 11. SEM of a $\sim 100 \mu\text{m}$ unmodified PE particle (Aspect 0) used in the production of Aspect supports (courtesy of Biosearch Technologies, Inc.).

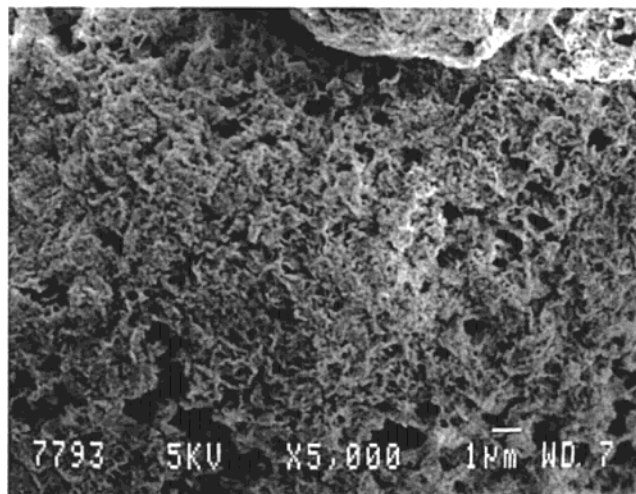

Figure 12. High-resolution SEM of the surface of a chemically eroded Aspect particle after prolonged treatment with oxygen in the presence of a transition metal catalyst (courtesy of Biosearch Technologies, Inc.).

Later, less vigorous conditions were developed, which also augmented the surface of the base particle. The base material was termed ASPECT 0⁹⁶ (see Figure 11), and subsequent products from alternative derivatization processes bear Roman numerals (e.g., Aspect IV produced by catalytic oxidation, shown in Figure 12). We were hopeful that Aspect would provide a useful alternative for large scale DNA synthesis, since the supply of CPG was very uncertain at the time and quite expensive. But, to cut a long story short, by the time we had tailored the processing to exactly duplicate the performance of CPG for DNA synthesis, our support was no longer quite so economical. In addition, the supply of high-quality CPG was assured from new sources, and the major application of large scale DNA synthesis, “antisense DNA”, looked like it was going to fizzle out. Undaunted, we have been busily trying to reconfigure the material for combinatorial chemistry, and have been able to perform some transformations with it that are impossible with conventional PS-based materials. Loading has very much been an issue, and polymer-coated variants solve this

problem. This story still is very much being played out, and the performance of variations of Aspect is discussed later. Only time will tell whether our efforts will prove worthwhile.

**Owen Gooding,⁹⁷ Jeff Labadie, and John Porco.
ArgoPore Resins: Macroporous Supports for
Solid-Phase Organic Synthesis**

The majority of solid-phase transformations described to date have employed lightly cross-linked (1–2%), gel-type polystyrene (GPS) supports, which have limitations related to the general requirement that the resins must be swollen in a suitable solvent to gain access to reactive sites. This gives rise to unique processes, such as gel-phase diffusion and solvent/reagent–polymer interactions, that must be considered when developing solid-phase reactions or transferring solution-phase chemistry to the solid phase. Macroporous⁹⁸ polystyrene resins are a well-known alternative to GPS resins for a variety of applications (vide infra). In the case of highly cross-linked (>8%) macroporous resins, chemical reactions involving functional groups occur primarily at the pore surface, with diffusion of reactants and products occurring through a pore network. We sought to develop a family of novel macroporous resin beads for solid-phase organic synthesis of small molecules, with high levels of cross-linking and high surface area. Aminomethyl, chloromethyl, and linker-modified resins were the subject of our investigation. Herein we describe the development, characterization, and use of such resins in several solid-phase synthetic transformations.⁹⁹

Macroporous polystyrene-*co*-divinylbenzene (MP) resins were invented in the 1950s and are widely used for ion-exchange, absorbents, and chromatographic separation media.¹⁰⁰ MP resins have largely supplanted lightly cross-linked, gel-type resins for these applications due to their resistance to solvent-induced fracture and lower swelling volumes. However, commercially available ion-exchange resins and absorbents were deemed nonideal for use as supports for solid-phase organic synthesis for a number of reasons.¹⁰¹ The available functional group types are limited, loading is generally too high (3–5 mmol/g), and bead size too large (~ 0.5 –1.0 mm). Loading to the maximum extent is desirable for ion-exchange applications, but it may lead to errors in synthesis when multiple steps are involved because not all sites are equally accessible. These large, highly loaded beads are also difficult to wash between synthetic steps due to a high percentage of small pores, i.e., pores $< 20 \text{ \AA}$ in diameter.¹⁰² A few companies¹⁰³ produce amino-functionalized MP resins for oligonucleotide synthesis that feature low loading and small bead size making them generally unsuitable for small molecule applications. We concluded that new macroporous supports that were designed for small-molecule applications would have great utility in parallel and combinatorial synthesis by providing an alternative to GPS.

The potential advantages of macroporous over gel-type supports include the following: (1) Rigid structure confines reactive sites to the pore surface rather than in the swollen gel phase. (2) Access of liquid reagents to reaction sites occurs by rapid diffusion through the rigid, open pore structure rather than through a swollen gel phase. (3)

Table 5. Typical Pore Data for Selected ArgoPore Resins^a

resin	average pore diameter (Å)	pore volume (mL/g)	surface area (m ² /g)
ArgoPore-NH ₂	90	0.95	650
ArgoPore-Cl	90	0.95	650
ArgoPore-Wang-OH	90	0.75	500

^a Pore data was determined by nitrogen adsorption.

Accessibility of reaction sites is independent of solvent type. (4) Accessibility of reaction sites is independent of temperature. (5) Swelling is low and predictable in all solvents, including water. (6) Potential exists for isolation of reactive sites from each other (site isolation). (7) Rapid and large volume changes during swelling provides resistance to bead cracking (osmotic shock). (8) Removal of reagents and byproducts through solvent washing between synthetic steps is rapid. (9) Solvent removal between synthetic steps (drying) is rapid. (10) Tendency to adhere to glass vessels is reduced.

Polymer Synthesis. Highly cross-linked polystyrene base resins ranging from 10 to 85% divinylbenzene (DVB) composition were investigated. The polymers were produced by analogy to published procedures employing free radical initiated suspension copolymerization of styrene and DVB with an inert diluent (porogen) added to create the porous structure.¹⁰⁴ These polymers were tested for pore size distribution, mechanical stability, washing characteristics, and ease of functionalization. Ultimately, a composition near the middle of the range was selected for further development. This base resin was functionalized by aminomethylation and chloromethylation using conventional methods to afford functional ArgoPore (AP) resins, AP-NH₂ and AP-Cl.¹⁰⁵

The pore structure of macroporous resins is best characterized by nitrogen adsorption-desorption measurements.¹⁰⁶ AP resins were found to have high total surface area, a low percentage of micropores (6 vol % pores < 20 Å), and a high percentage of mesopores (94 vol % pores 60–200 Å) (Table 5). High surface area is desirable because ultimate loading is proportional to surface area. Low micropore volume is desirable because small pores are inaccessible to larger reagents and smaller reagents can become trapped leading to difficult washing operations. High mesopore volume is also desirable as mesopores facilitate bulk transport of reagents and solvents in to and out of the bead. Because the easiest way to obtain high surface area is to have a large number of small pores, it seems the ideal pore structure is a delicate balance between pore geometry and surface area. Macropores (pores > 200 Å) are undesirable because large pores do not provide adequate surface area for reasonable levels of functionalization. Through resin functionalization we were able to obtain relatively high loading (0.6–1.2 mmol/g) in comparison with other MP resins due to the high surface area and uniform pore structure (Table 5).¹⁰⁷

Swelling. Solvent-induced volume changes are an important consideration for solid supports. The density of dry AP resin is low (0.4 g/mL, 2.5 mL/g swelling) relative to GPS due to its porous nature (it's full of air!). In contrast to GPS resins, swelling for AP-NH₂ is relatively constant over a wide range of solvents, including MeOH and water (Figure 13). The volume increase from 2.5 to 4.5 mL/g in the presence of solvent is attributed to pore expansion upon solvent regain

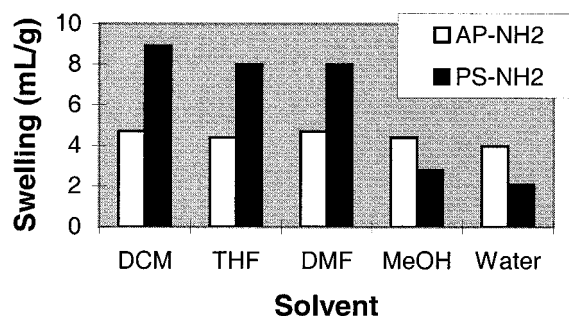

Figure 13. Swelling of ArgoPore (AP-NH₂) compared with gel-type PS (PS-NH₂).

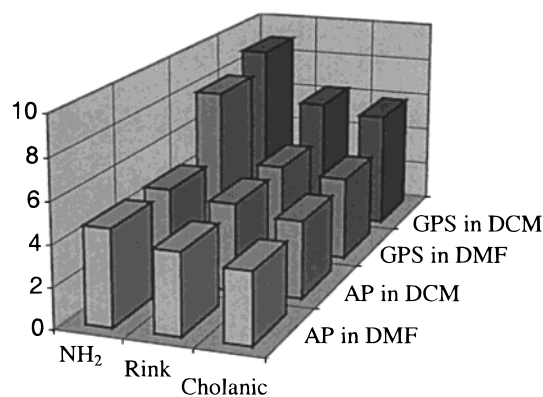

Figure 14. Effect of small molecule attachment on resin swelling.

rather than gel-phase swelling associated with lightly cross-linked polystyrene supports.

The swelling of AP is largely independent of the bound molecules (Figure 14). Attachment of the Rink linker and subsequent loading of cholanic acid (a steroidal carboxylic acid) causes a relatively small decrease in swelling for AP resins. In fact, when normalized for the polystyrene composition, there is no significant swelling change due to the attached small molecule for AP resins. In contrast, swelling changes dramatically upon small molecule attachment to the gel-type polystyrene which is highly dependent on the nature of bound molecules and not always predictable. This capricious behavior can lead to “eruptions” of resins out of their vessels (e.g., IRORI Kans) during synthetic operations employing GPS.

Washing. A ubiquitous operation in solid-phase synthesis is the removal of impurities and byproducts between steps through resin washing. A great deal of time and solvent is consumed by this activity (thank goodness it can be automated!). To compare washing properties of two resins, AP-Wang and GPS-Wang were each impregnated with a solution of biphenyl in DCM by agitation for 1 h (100 mg of resin, 4 mL of solution, 32 mg/mL). Washing with 4 mL aliquots of DCM was continued and the release of biphenyl was monitored by GC using naphthalene as an internal

Table 6. Resin Washing Study

resin	% biphenyl removed			
	wash 1	wash 2	wash 3	wash 4
ArgoPore-Wang	92.1	8.0	0.01	0
Gel-type-Wang ^a	81.85	14.98	2.62	0.01

^a Obtained from Novabiochem, 0.9 mmol/g.

Table 7. Suzuki Coupling Results

resin type	loading (mmol/g)	aryl halide	boronic acid	% recovery ^a	% HPLC purity ^b	% conversion ^c
ArgoPore	0.45	2-iodobenzoic acid	<i>o</i> -tolyl	55	100	91
Gel-type	0.52	2-iodobenzoic acid	<i>o</i> -tolyl	56	100	89
ArgoPore	0.45	2-iodobenzoic acid	<i>o</i> -tolyl	61	100	92
Gel-type	0.52	2-iodobenzoic acid	<i>o</i> -tolyl	56	100	90
ArgoPore	0.45	4-iodobenzoic acid	<i>o</i> -tolyl	93	100	91
Gel-type	0.46	4-iodobenzoic acid	<i>o</i> -tolyl	89	100	100
ArgoPore	0.45	4-iodobenzoic acid	<i>p</i> -methoxyphenyl	97	100	97
Gel-type	0.43	4-iodobenzoic acid	<i>p</i> -methoxyphenyl	78	100	96
ArgoPore	0.33	2-bromonaphthoic acid	naphthyl	77	34	34
Gel-type	0.35	2-bromonaphthoic acid	naphthyl	72	28	28

^a Total mass recovery. ^b Purity relative to side products. ^c Obtained by integration of product relative to starting material.

Table 8. Enolate Alkylation Results

resin type	<i>n</i>	base/temp (°C)	R ₁ X	% recovery ^a	% purity ^b HPLC	% conversion ^c HPLC
GPS ^d	1	LDA/0	BnBr	98	98	42
AP	1	LDA/0	BnBr	65	97	99
GPS	1	LDA/−78	BnBr	93	100	0
AP	1	LDA/−78	BnBr	93	100	92
AP	1	LiHMDS/0	BnBr	66	97	99
AP	1	LiHMDS/0	EtI	67	97	97
AP	1	LiHMDS/0	MeI	66	94	92
AP	2	LDA/0	BnBr	57	95	97
AP	2	LiHMDS/0	BnBr	65	96	97

^a Total mass recovery. ^b Purity of the product relative to side products. ^c Obtained by integration of the product relative to the starting material. ^d Aminomethyl resin (1% cross-linked) obtained from Bachem.

standard. Biphenyl was removed at a higher rate, and with fewer washes, from AP relative to GPS (Table 6). Wash times of 2 min were sufficient for bead-solution equilibration of impurities (longer wash times were not more effective).

Supported Synthesis. The Suzuki reaction is a transformation known to work particularly well on solid phase.¹⁰⁸ As an initial test of the general utility of AP resins, a comparative study of biaryl couplings was conducted using the Nautilus 2400 automated synthesizer (Argonaut Technologies). AP-Rink-NH-Fmoc was prepared from AP-NH₂ resin of 0.75 mmol/g loading and GPS-Rink was prepared from GPS aminomethyl resin of loading 0.8 mmol/g so that resins of similar loading were employed. Polymer-supported *o*- and *p*-iodobenzoic acids or 2-bromonaphthoic acids were coupled with *o*-tolyl, *p*-methoxyphenyl, and naphthalene boronic acids in the presence of Pd(II) catalyst (Figure 9B). Results showed that AP performed similarly to GPS in most cases (Table 7).

Enolate alkylation is a fundamental C–C bond-forming reaction widely employed in solution-phase synthesis, but it has enjoyed limited success on solid phase due to the low temperatures required.¹⁰⁹ A study was initiated to compare AP to GPS for this low-temperature application. The Kenner aryl sulfonamide “safety-catch” linker was employed to anchor phenylacetic or phenylpropionic acid to the resin (Figure 9C).¹¹⁰ Deprotonations were effected with 3.3 equiv of LDA or LiHMDS at 0 or −78 °C prior to addition of the electrophile. Alkylations were allowed to reach ambient temperature for 6–12 h prior to quench, cleavage, and analysis.

Excellent conversions were achieved with AP resins at either temperature (Table 8). Lower recoveries from reactions at 0 °C were attributed to cleavage of the linker during the

reaction at higher than normal temperature. The GPS gave poor conversion at 0 °C and no reaction at −78 °C. No characteristic color change associated with trianion formation was observed with GPS at −78 °C whereas the AP resins turned green instantaneously upon addition of base. The poor performance of GPS was attributed to anion-induced deswelling of the material at low temperature. This example highlighted advantages offered by ArgoPore over GPS for certain reactions involving anion chemistry and low temperature. We have also successfully demonstrated other chemistry on ArgoPore ranging from aqueous reactions (nitro group reductions and periodate olefin oxidations) to anion chemistry (Weinreb amide alkylations).¹¹¹

With these results in hand we felt confident in releasing ArgoPore resin products to the general community as an alternative to typical gel-type polystyrene supports for small molecule applications. Product launch occurred in June 1997 with the offering of hydroxymethyl, chloromethyl, aminomethyl (three loading levels), and four linker derivatives. Since commercial introduction, ArgoPore resins have experienced increased use in both academia and industrial discovery groups as they continue to enjoy their place in the combinatorial chemist’s toolbox.

Alex Andrus.¹¹² Meeting the World’s Insatiable Demand for Oligonucleotides

Our interest in developing a better DNA synthesis support began in the mid 1980s when it was clear that the combination of the phosphoramidite chemistry method and automated synthesizers was enabling people everywhere to make their own oligonucleotides. The practice had passed from the hands of a few experts to the consumers, the researchers that used oligos in their experiments. Applied Biosystems,

Biosearch, Pharmacia, and several other companies had a sum total of about 500 synthesizers spread around the world in universities, medical centers, and at biotech and drug companies. Phosphoramidites cost about \$150 per gram and the total costs for making an oligo were about \$7 per base. Each base addition took about 15–20 min. Making an oligonucleotide was a day long process, but researchers loved the machines because it was completely automated, humming along in the lab while they were busy with cloning, radiolabeling, centrifuging, etc. Many of our customers told me the click-click-click sound of the valves opening and closing became so rhythmically compelling it had their lab group practically dancing at their benches (alright, I'm exaggerating).

In those years prior to PCR and automated DNA sequencing, practically no one foresaw oligonucleotide production becoming centralized as it has now. Our research group in 1986 was going full throttle at refining "amidite" chemistry, developing the next generation of synthesizers, and trying to find other ways to get oligos into people's hands. Customers kept telling us that synthesis was not the problem, but that purification was the real bottleneck. The dogma then was that every oligo was suspect and must be rigorously purified and analyzed. Those with a life science background favored polyacrylamide gel electrophoresis, while chemists favored HPLC. Each method had its incurable drawbacks, some combination of too expensive, unreliable, inefficient, or slow. We initially tried to facilitate the situation by elevating the purity of the oligo before it came off the synthesis support. The support of choice was glass²⁴ and later evolved as controlled-pore-glass, "CPG".¹¹³ The properties of CPG were a good match for automated synthesis of oligos using the phosphoramidite method. The CPG could be easily derivatized and loaded with the first nucleoside, reactions were very rapid, reagents washed off very quickly, and the finished oligo could be easily cleaved.

We learned, however, that CPG had problems. The particles were fragile, got crushed, and clogged the frits and synthesizer plumbing. Even worse, side reactions during oligo synthesis made purification difficult. In searching for alternatives, Molecular Biosystems sold us a small jar of a curious support for oligo synthesis consisting of a ribonucleoside bound to Teflon wool through an ammonia stable linker, for \$10,000. We started experiments to see if we could remove the impurities while the 5'-DMT oligo was still on the Teflon support. The oligo was cleaved under oxidative conditions, and as an incidental final step to the process, we isolated the DMT oligo from the cleavage reagents by passage through a Waters C18 Sep-Pak cartridge. After a lot of work and only marginal success, we realized it was this final step that imparted the greatest purification effect, so we began to cast about for improvements to a cartridge-based purification media selective for the hydrophobic DMT group, which theoretically only the correct-sequence oligo should have. We recognized that the ideal method would use the crude oligo directly from the ammonium hydroxide solution after cleavage and deprotection. The C18 reverse-phase silica in the Sep-Pak was inadequate because it was not stable to ammonia. The ideal method should also give

the purified oligo by a rapid little protocol in aqueous solution, ready to take an aliquot directly into the researcher's experiment.

Polystyrene was touted as an improvement over reverse-phase silica as an HPLC adsorbent for biopolymers. We made the extrapolation to our purification ideas and began to look into the surprisingly (none of us were polymer chemists) numerous forms of polystyrene beads, their parameters, and the suspension polymerization process of Rohm and Haas, dating back to the mid 1950s.¹¹⁴ We tested samples from several vendors and indeed found that highly cross-linked, rigid, and nonswelling polystyrene beads had a remarkable affinity for DMT oligos. Under the right conditions, we could get complete binding just by passing the ammonium hydroxide solution through a cartridge filled with the beads and virtually no binding of non-DMT oligos. The cartridge could then be washed with any volume of aqueous solution to remove the ammonia and other impurities while retaining the DMT oligo, which could be immediately eluted by adding a small amount of an organic solvent like methanol or acetonitrile. It wasn't long before we had a nice little protocol worked out which still called for a final detritylation step. We eliminated that step by finding that we could detritylate the DMT oligo and keep it on the beads in the cartridge with a low concentration of trifluoroacetic acid. That protocol and that product was released as the Oligonucleotide Purification Cartridge (OPC) in January 1988.¹¹⁵ There was nothing like it at the time, and OPC was an immediate, enduring success.

We recognized that this type of polystyrene might be useful as a synthesis support as well. Nucleic acid chemists had been put off from polystyrene from earlier work that showed poor results when Merrifield type polystyrene, being of low cross-linking and swelling, was used with the earlier phosphodiester and phosphotriester methods. Being largely unaware of these attempts and ignorant of polymers in general, we began to make oligos on the same polystyrene we used in our OPC cartridges. Our peptide synthesis friends showed us how to derivatize the polystyrene with an aminomethyl group which we coupled with the standard 3'-succinate nucleosides. Several publications suggested that linker type or length had a bearing on oligo synthesis efficiency, and we did not investigate longer linkers beyond a few experiments. The initial results were very promising, making phosphodiester and antisense phosphorothioate oligos with excellent efficiency, including some 200 μ mol scale syntheses. We ended up playing with the pore size, pore volume, and particle size parameters. With a cross link content of about 50% divinylbenzene, these polystyrene beads were rigid and nonswelling, ideally suited to conduct rapid reaction kinetics and efficient washing. The first polystyrene synthesis support product was released in 1991 as 40 nmol scale columns.^{116,117} The polystyrene columns enabled oligo synthesis for about \$1 per base and a cycle time of about 5 min at very high efficiency (>98% average yield per cycle).

With the advent of PCR and automated DNA sequencing, the demand for oligos exploded. In 1995, we introduced the only commercially available, high-throughput synthesizer,

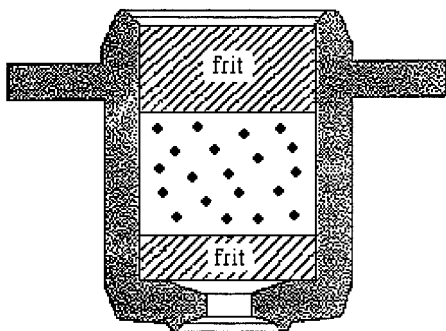

Figure 15. OneStep synthesis and purification cartridge.

the Model 3948, and combined the synthesis and purification operations on a single column (Figure 15).¹¹⁸ The OneStep column has a mix of 3'-nucleoside-loaded polystyrene for synthesis and underivatized polystyrene for purification. The synthesized oligo is cleaved, transferred to a heating coil for deprotection, and then transferred back to the same OneStep column for the purification protocol. On the way to the collection rack, oligos are quantitated by a UV light source. With complete automation, 48 oligos of average length are produced in a day. We have also found that polystyrene is a great support for derivatized and labeled oligos. So, our polystyrene products have been useful for meeting the world's insatiable demand for oligos.

Joseph Buettner.¹¹⁹ Evolution of Resins for Selection of Affinity Ligands

The world of affinity chromatography has recently experienced a boom in attention. Rapid and complete purification of proteins from complex mixtures is demanded by researchers in benchtop to production floor column volumes. Historically, most affinity ligands were themselves receptors for the protein (antibodies). Although very popular at the bench, use of antibody ligands in manufacturing scale columns are very expensive and pose numerous hurdles. One problem is sanitization of the resin (most of the chemicals that kill virus and bacteria also attenuate the antibody ligand's recognition of the target protein, severely depleting column life). Others involve cost of goods from large scale culture, lot-to-lot consistency, and the problems associated with animal proteins in cell culture (viruses, prions, etc.). Hence the drive recently has been to identify peptides or small molecule ligands that not only are specific (resulting in a good column selectivity and consequent enhanced purification) but also allow avid binding and high densities (providing high column capacity). Several methodologies have been proposed for identifying peptide ligands; the most popular in the literature is phage display.^{120,121} Here peptides are randomly generated (one sequence per phage) and selected for phage binding on the target protein. In our experience, many phage sequences that bind the target protein in solution or on biopanning plates lose their binding capacity when linked onto or directly synthesized on chromatography resins. The molecular presentation of the peptide on the phage must be significantly different than on the resin, so much so that the target protein often binds poorly, if at all. Our early work to demonstrate whether peptide ligands derived from libraries would bind and purify proteins¹²² used a phage-derived peptide sequence

containing HPQ for binding and purification of streptavidin. However, not all of the HPQ-containing sequences bound or purified the streptavidin when linked onto a resin matrix. With this initial demonstration that affinity ligands can be identified from libraries, the race to identify unique affinity ligands was on.

Our primary consideration in selection of affinity ligands was to rapidly screen libraries of ligands under chromatography conditions (that is on-resin), to select for target protein binding, to discriminate against binding of contaminants, and to elute biologically active protein (ligate) from the resin. At that time peptide synthesis resins were mostly based upon cross-linked polystyrene (inherently hydrophobic, even after incorporation of hydrophilic adducts). In our hands, non-specific binding was a problem with such polymers, rendering them useless as purification resins. Thus, our group modified an existing chromatography resin to allow high-quality peptide or peptidomimetic synthesis, yet allowed it to retain the necessary characteristics of a good chromatography resin (hydrophilic, large pores, controllable substitution, controllable spacer arm for proper molecular presentation of the ligand, and bead rigidity to withstand large column volumes). The resin described here, based upon TosoHaas' poly-hydroxylated methacrylate resin, provides for all these parameters. Concurrently we developed a subtractive, chromatography-based library screening method which identified peptide ligands for various target proteins under various chromatography conditions.¹²³ Our methodology, affectionately called the PELICAN technique,¹²⁴ has identified nanomolar-strength binding ligands to several blood proteins. The PELICAN technique will screen $1-2 \times 10^6$ resin beads (peptides) with a turnaround time of 2 days in a chromatography format (easily scalable). The sequences identified are then batch synthesized on the same resin at the same ligand density and used in a 0.5 mL affinity column format to confirm target protein binding and ascertain purification parameters.

The foundation for all the PELICAN screens was the chemical manipulation of the base resin. Several different modifications to the TosoHaas Chelate resin allowed for efficient peptide synthesis; but controlling ligand density was difficult. The chelate moiety was changed to a primary amine with a 15 atom spacer arm (4,7,10-trioxa-1,13-tridecanediamine, Totda, Fluka) by standard coupling techniques. However, driving the Totda substitution also acylated available hydroxyls which increased the substitution level. The high ligand density made Edman sequencing of a single bead easy, but if the ligand density was too high, the column would become nonselective in its binding and purification was compromised. A scanning EM photomicrograph of a 65 μm resin bead is shown in Figure 16. This particular bead had been used in a PELICAN library screen, and the damage to the bead is most likely caused by pressure during column packing. The large surface area of the bead is readily discernible (the bead looks like a sponge). We were able to obtain the base resin with the amino substitution already present in different bead diameters with virtually the same pore size distribution.¹²⁵ Careful sieving for narrow bead diameters¹²⁶ gave us several bead populations from 50 to

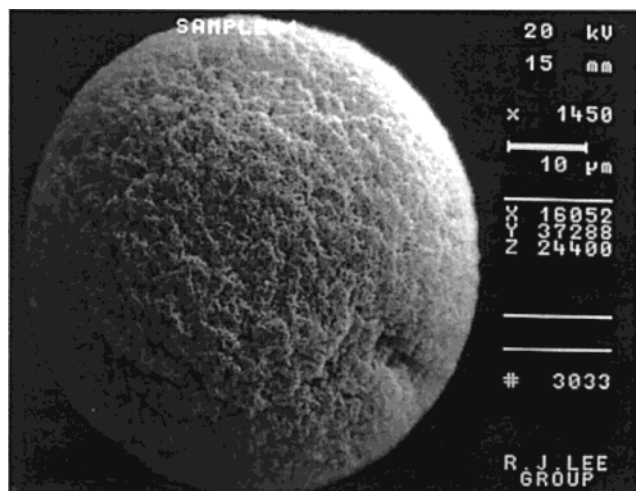

Figure 16. SEM of 65 μm Pelican bead recovered from library screen.

>200 μm diameters. To control ligand density the amine density was decreased by mixing different ratios of tBoc- and Fmoc-protected alanine for the first coupling, deblocking the tBoc- and acetylating the resin, then using the Fmoc arm for peptide synthesis. Different lengths of linker arm and ligand residue lengths were also explored. By using aspartic acid as the amino terminal residue of the peptide and a cleavable linking system on the resin, we cross-linked the amino termini of ligands that were in close proximity, thereby demonstrating what length of linker, length of ligand, and ligand density were appropriate for any size particle. By substituting the resin at this optimized density we maximized binding capacity (i.e., column capacity); by extending our linker arm we allowed for the ligand to bind in deeper clefts on the target molecule; and by using different size beads (at the same linker length and density) we allowed for better identification of the ligand (Edman sequencing of peptides and mass spectral analysis of peptidomimetics), yet preserved diversity in our libraries by increasing the total number of beads and synthesizing longer ligands. Our final screening and purification resin was 120–160 μm diameter, 100 $\mu\text{mol/g}$ substitution, a spacer arm of up to two γ -aminobutyric acid residues, and a peptide length of six to eight residues. At this level of substitution, an individual bead has approximately 80 pmol of peptide ligand measured by Edman sequencing (results not shown).

There are as many different linkage chemistries as there are different assay applications. We arbitrarily grouped the linkers into three types of release: soft release, hard release, and no release chemistries. Soft release chemistries are stable to all synthesis and deblocking conditions and include photolabile linkers or redox linkers that have release conditions that are compatible with cellular growth or on-resin cell-based assays. Hard release chemistries include linkers that are stable to all the synthesis and deblocking conditions but release when a particular chemical is applied to the bead (the treatment in this case would harm cells). A good example of a hard release linker is the hydroxymethylbenzoic acid linker. This linker is stable to strong acids and medium-strength bases such as piperidine, but it is labile to strong bases such as hydroxide and primary amines such as



Figure 17. Single Pelican bead in electro-spray nanoprobe needle.

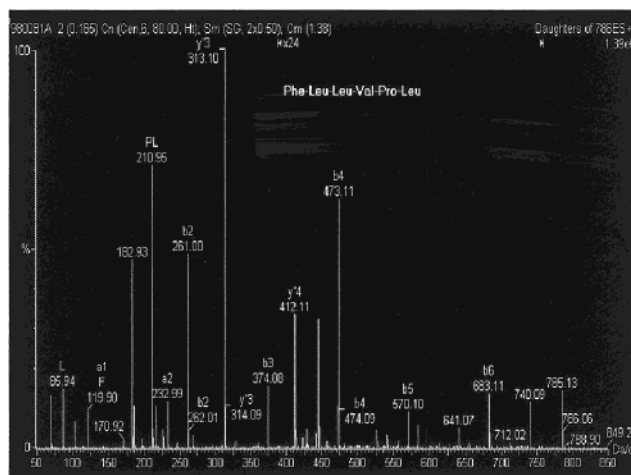

Figure 18. M/S deconvolution of natural peptide ligand identified by Pelican technique.

ethylamine. It is interesting to note that some linkers act as both hard and soft release depending upon conditions. Some photolabile linkers can release under harsh conditions such as ethylamine. This allows for a selective proportion of ligands to release off the resin at will for identification of a biological response, then the bead is isolated, and the structure is identified by hard release of the rest of the ligand. Our soft release linker is the NuLinker.¹²⁷ This linker allows soft release by photolysis (long wavelength ultraviolet irradiation) and allows for hard release with ethylamine gas. Figure 17 shows a single bead in a nanoprobe needle for electro-spray mass spectral analysis.¹²⁸ A single bead was placed into the nanospray needle tip in methanol, the methanol was blown dry seating the bead on the interior of the needle, and then ethylamine gas was streamed through the needle cleaving the peptide off the resin giving a carboxyl terminus ethylamide. Nanospray analysis of the bead-needle gives about 45 min of signal which is usually plenty of time for sequence identification of the ligand.^{129,130} Figure 18 is a control sequence deconvolution of a natural amino acid peptide ligand identified by the PELICAN technique. Fragment ions of B and Y ions are readily discernible. Sequence determination of natural amino acid peptide ligands from PELICAN is straightforward: we simply load the individual bead into a Hewlett-Packard G1005A and perform Edman degradation. But sequence or structure elucidation of mimetic

Table 9. Binding Parameters for Library-Derived Peptide Ligands in Solution versus On-Resin (*bold italics*)

target protein: peptide ligand	K_D (μM)	ΔH° (kcal/mol)	ΔS° (eu)	ΔG° (kcal/mol)
human factor IX zymogen: YANKGY in solution	920	+5.8	+35	-4.2
<i>YANKGY-TosoHaas beads</i>	<i>0.011</i>	<i>-200</i>	<i>-690</i>	<i>-11</i>
human α -thrombin (factor IIa): HQLWGS in solution	14	+13	+70	-6.7
<i>HQLWGS-TosoHaas beads</i>	<i>0.003</i>	<i>+96</i>	<i>+390</i>	<i>-11</i>
human prothrombin (factor II): YFPGPYL in solution	29	+3.1	+33	-6.3
<i>YFPGPYL-TosoHaas beads</i>	<i>0.022</i>	<i>-48</i>	<i>-140</i>	<i>-11</i>
human α 1 proteinase inhibitor: VIWLVR (not soluble)				
<i>VIWLVR-TosoHaas beads</i>	<i>0.087</i>	<i>+31</i>	<i>+130</i>	<i>-9.8</i>
ribonuclease S protein: YNFEVL in solution	1.8	-42	-130	-8.0
<i>YNFEVL-TosoHaas beads</i>	<i>15</i>	<i>+140</i>	<i>+530</i>	<i>-6.7</i>

ligands must use the mass spectrometer. We are currently developing a database of fragmentation patterns found for a variety of nonnatural amino acid derivatives in order to create and probe mimetic libraries.

The modified TosoHaas bead has been successively used to identify peptide ligands for a variety of plasma proteins. Several techniques have been used to determine the binding avidities and stoichiometries.^{131,132} Isothermal titration calorimetry¹³³ (ITC) measures the heat flux which accompanies all binding events, including those between a macromolecule (target protein) and a potential ligand (peptide or peptidomimetic). With ITC, in a single experiment, an accurate measurement of the association constant (K_A , M^{-1}), Gibbs free energy of binding (ΔG , kcal/mol), the enthalpic change which accompanies binding (ΔH , kcal/mol), the entropic change which accompanies binding (ΔS , eu), and the stoichiometry of binding can all be calculated. The arithmetic sign (+ or -) of the enthalpic and entropic terms also gives insight into the mode of binding between target protein and ligand; a large and negative enthalpic term usually means that binding is mediated by strong interactive forces such as electrostatic interactions, while a large and positive entropic term usually means that conformational changes in the ligand or target protein or both play a role in binding. Table 9 shows some of the different ligand:ligate pairs that have been investigated.

Of particular importance, the binding avidity increased 1–2 orders of magnitude when PELICAN-derived ligands are immobilized on resins compared to solution-phase binding with the same ligand/ligate pair. With all pairs, the Gibbs free energy was negative, indicative of favorable binding. The modality of binding sometimes switches between resin binding and solution-phase binding: what may be an entropically driven reaction in solution phase may be enthalpically driven on the solid phase. This supports the premise that ligands immobilized on the solid phase form binding “surfaces” for their appropriate ligates and that these binding surfaces seek complimentary “surfaces” on the target protein. This helps us explain column specificity. We also have demonstrated that the higher the ligand density on the resin, the more avid the binding.

Stoichiometry can usually be measured for solution-phase binding, and we have seen stoichiometries from 1 to

approaching 20 ligand-equivalents per protein molecule. However, binding stoichiometries on the solid resin are more difficult to measure because we know that all ligands are not physically available for binding and we have not saturated the peptide-resin with ligate.

We have only investigated the binding parameters of one affinity ligand derived from a phage display library by ITC. This is the ribonuclease S protein and its ligand YNFEVL.^{134,135} In both cases the Gibbs free energy of binding is negative, and interestingly, the dissociation constant is weaker on-resin. However, note the switch in binding modalities between solution phase and solid phase: in solution phase, binding was enthalpically driven, but on the solid phase, binding was entropically driven. The peptide is displayed on the phage linked by its amino terminus and with its carboxyl terminus free, while on-resin the carboxyl terminus is immobilized while the amino terminus is free. Therefore, the resin may sterically block the complete binding of the protein thus weakening the interaction. This may be why free YNFEVL peptide will effectively desorb the protein from the resin, but free PELICAN-derived ligands do not compete for bound protein (results not shown). This does, however, underscore the rationale to screen for ligands on-resin if your intended use for the ligands is on-resin, and screen in-solution if your intended use for the ligand is in-solution.

Conclusions.¹³⁶ Resin design is the cornerstone of a successful on-resin screening program. Improper choice of resin can give false positive results from nonspecific binding during the screening or compromise the selectivity (purification) of the final affinity column. We have developed a resin providing good synthesis efficiency suitable for the synthesis of libraries of compounds (under controlled density), screening of the libraries on-resin, and analysis of the binding properties on-resin, while still allowing control of the synthesis parameters for large scale column generation. The base resin from TosoHaas provides the desired hydrophilicity and the mechanical rigidity; while controlled chemical modification of the density and linker length allows for differential ligand presentation which directly affects column performance for protein load and purification.

Steven P. Adams.¹³⁷ Controlled Pore Glass as a Solid Support for Organic Synthesis

Controlled pore glass (CPG) found its way into the solid-phase chemical synthesis literature early in the advent of DNA synthesis by the phosphoramidite approach. The use of CPG came about by necessity because as the molecular biologists conducting the biotechnology revolution designed increasingly sophisticated gene cloning and expression vectors, they demanded ever longer synthetic DNA fragments to achieve their objectives. Moreover, the purity and sequence fidelity of the synthetic DNA fragments became paramount considerations, especially when assembling synthetic genes. The phosphoramidite synthesis method on CPG supports succeeded in delivering the needed performance.

I joined Monsanto Company's fledgling biotechnology division in 1980 as Ernie Jaworski was beginning to build a team to develop plant transformation systems, expression vectors for cattle and swine growth factors and to conduct discovery research directed toward human therapeutics. As the inaugural chemist in the division, my first assignment, together with my molecular biologist colleague Jerry Galluppi, was to institute a DNA synthesis capability that would serve the needs of the molecular biology effort. Just as we were getting started, Beaucage and Caruthers published their seminal paper on the phosphoramidite method of DNA synthesis²⁶ that expanded on the pioneering work of Letsinger,^{21,22} who originally introduced the phosphite approach. They employed nucleoside dimethylphosphoramidite reagents and aminopropyl-functionalized silica as the solid support to which one of the four 5'-protected deoxynucleosides, corresponding to the 3'-end of an intended synthetic fragment, had been attached through a succinate linker. DNA fragments were prepared by successive cycles of 5'-deprotection, reaction with a nucleoside phosphoramidite reagent, oxidation of phosphite to phosphate, and capping of any unreacted 5'-hydroxyl groups to terminate "failure sequences"; extensive washing of the support was conducted at each step of the synthesis.

In our experience with the Caruthers procedure it was possible to achieve a 95–98% yield in each cycle using a 10–30-fold excess of phosphoramidite to drive the condensation reaction. The inert, nonswelling, nonretentive silica support was fundamental to this level of performance in that it provided for efficient washing to remove acidic and nucleophilic impurities prior to the condensation reaction, a paramount requirement due to the extreme reactivity of the phosphoramidites. With this support it was possible to routinely prepare fragments 20–25 nucleotides in length before failure sequences, particularly sequences one residue shorter than the intended target ($n - 1$ sequences in the parlance), began to accumulate to levels that confounded purification by HPLC or by SDS–PAGE. Upon careful examination of products it became clear that failure sequences were accumulating at low levels throughout the synthesis, 1–3% in each synthetic cycle, and that incomplete reaction was particularly apparent in the first 5–10 cycles. This appeared to be an effect of the support, and we hypothesized that initial functionalization of the silica installed a fraction of aminopropyl groups at sites that were

less accessible and relatively less reactive, even to small, highly reactive capping agents. We reasoned further that the narrow, and relatively less consistent, pore sizes available in most HPLC-grade silica support materials at the time could account for this observation; this followed from the observation that the best results, in our hands, were obtained with nonspherical 300 Å pore size Vydac silica. About this same time in 1981, our colleagues working on plant transformation arrived in the lab with a request for several complex linkers 45–50 nucleotides in length to facilitate vector construction. Initial synthesis attempts on silica supports failed to deliver useable material, so the far more laborious approach of ligating smaller synthetic fragments was undertaken to provide the needed materials. Taken together, these experiences pointed to the need for a support with more uniform reactivity across all reaction sites and larger pore sizes to accommodate larger DNA fragments that would improve yields and allow for the preparation of longer sequences.

During the time we were struggling with the solid support issues, Kamila Kavka joined us from Washington University where she had worked with CPG as a size-exclusion and protein affinity matrix, and she enthusiastically promoted its possibilities as a synthesis support. A search of the literature failed to reveal any applications to DNA synthesis,¹³⁸ but the superior character of CPG that had supported specialized protein applications quickly became apparent in DNA synthesis. When functionalized with long-chain alkylamine groups, the coated glass with 500 Å pore size exhibited exceptional properties: it was rigid, nonswelling, and mechanically stable across the range of solvent polarity; it was chemically stable from pH 1–14, unreactive to a broad range of nucleophilic and electrophilic reagents, and stable to heating; and it exhibited excellent solvation and flow properties. Most importantly, the amino functionality displayed consistent, high reactivity across all sites in the initial condensation with 3'-succinoyl nucleosides, and 5'-hydroxyl groups on the growing DNA chain likewise remained accessible to the phosphoramidite reagents thus facilitating nearly quantitative coupling reactions. The first experiments showed great promise for delivering very long sequences as repetitive cycle yields in excess of 98–99% were consistently obtained across a range of different sequences. Using the more stable, yet highly reactive, diisopropyl phosphoramidites, it became possible, even trivial, to synthesize DNA fragments that were, for the time, of monumental lengths. Our work was reported at the ACS Meeting in Las Vegas, March 1982, and published in *J. Am. Chem. Soc.* in 1983.¹³⁹ It was a very exciting time.

We attributed much of the improvement provided by CPG to its consistent, large pore size which allowed for effective diffusion of solvents and reagents and sterically accommodated the larger fragments. The irregular shape of the particles also appeared to prevent the CPG from packing into dense beds during reaction and filtration steps, which facilitated solvation and flow characteristics. The irregular shape is obvious from the optical microscope image of 1000 Å CPG shown in Figure 19, whereas the consistent nature of the pore structure is clearly seen in the scanning electron micrograph of the same material (Figure 20).



Figure 19. Optical microscopy of functionalized 1000 Å CPG (photograph courtesy of Biosearch Technologies, Inc.).

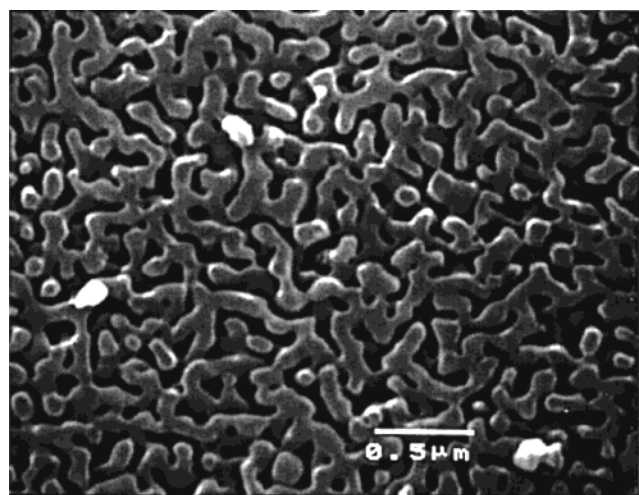

Figure 20. SEM image of a section of CPG identical to that shown in Figure 19 (photograph courtesy of Prime Synthesis Inc., Aston, PA).

The exceptional performance characteristics of CPG in the phosphoramidite method of DNA synthesis have served the DNA chemistry and molecular biology communities very well as evidenced by the extent to which the method has been applied and the durability of CPG use since it was introduced 18 years ago. Moreover, further innovations with CPG have appeared relating to linker design, alternative coupling chemistries, and application to RNA synthesis, not to mention continued refinements in high-performance affinity methods and immobilized biocatalysis. On the basis of its inertness and compatibility with such a broad range of chemistries, it is surprising that CPG has not yet found broad application outside the fields of DNA and RNA synthesis. While this may be simply because the solid-phase organic chemistry and combinatorial chemistry communities have grown out of fields unfamiliar with the use of CPG in polynucleotide synthesis, it is possible that unpublished efforts to employ CPG more broadly have been less promising. CPG does have limitations:

(1) It appeared in our early studies with silica and CPG supports, which have been largely confirmed to date, that optimal performance was obtained only on supports with relatively low functional group loading; indeed, cycle yields

fell significantly in DNA synthesis if loading exceeded 20–50 $\mu\text{mol/g}$. Fmoc-mediated peptide synthesis on a similarly low-loaded spacer arm functionalized CPG proceeded satisfactorily,¹⁴⁰ but highly functionalized CPG lacking spacer arms gave very poor yields,¹⁴¹ consistent with DNA synthesis experience.

(2) CPG surfaces, even when coated, are polar and retain partial negative charge which may compromise CPG performance in some settings where hydrophobic surface properties are important. Possibly for this reason, large scale synthesis of phosphorothioate DNA gave better yields on TentaGel than on CPG.¹⁴²

(3) CPG and silica, in general, will not tolerate fluoride reagents and highly corrosive chemicals.

(4) Until recently, the cost of CPG on a functional group basis has been rather high; however, improved economics due to increased manufacturing capacity established to support the DNA synthesis market has lowered costs.

Whatever the reason for slow uptake into the solid-phase organic synthesis field, CPG offers some distinctive advantages compared to traditional polymeric supports.¹⁴³ The performance characteristics of CPG may yet invite its use in demanding synthesis applications where the limitations of low loading, surface polarity, incompatibility with fluoride, and cost are not important considerations.¹⁴⁴

Barry A. Morgan,¹⁴⁵ “Peptides at the Beach”: A Perspective on an Adventure in the Design and Exploitation of Immobilized Peptide Libraries as Substrates for Proteases

The concept of what synthetic chemists now refer to as “high-throughput synthesis” became evident to me, and many others at the 10th American Peptide Symposium in St. Louis in May 1987. In a session on peptide synthesis, the audience had just heard from Richard Houghten¹⁴⁶ that peptides could be made at the rate of around 100 per month using small polypropylene mesh packets, called “teabags”. At the time this was an impressive accomplishment, but in terms of numbers, it was due to be upstaged by the very next speaker. Mario Geysen¹⁴⁷ walked up to the stage, dumped his duffel bag down at the side of the podium, and proceeded to outline the work of his group, who, we learned, could easily make 50 nM amounts of 1000 peptides in a month! This synthesis took place on the end of polyacrylate rods arranged in arrays to fit a microtiter plate format. This level of productivity was indeed impressive! The ability to make large numbers of peptides with sequences designed to comprehensively define biological patterns, or, in other words, to establish a structure–activity relationship in one synthesis-assay cycle had enormous appeal.

I returned to my laboratory eager to apply the concept of “high-throughput synthesis” to our own research problems. The opportunity came when Larry Kruse, the newly appointed vice-president for Chemistry at Sterling Research, asked me to think about how a technology might be developed to probe substrate selectivity for a family of related proteases.

Substrate selectivity is a fundamental property of protease action and is of primary importance in the characterization

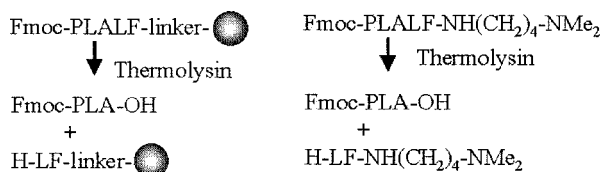

Figure 21. Test of the concept of enzymatic cleavage of immobilized substrates.

of the protease, in the mechanism-based design of inhibitors, and in the determination of physiological function. In practice, some knowledge of substrate selectivity must be known before protease action can be identified, as protease assays are without exception based on the ability to cleave a peptide or protein sequence. Expansion of this initial single primary sequence to a more comprehensive understanding of what structures are allowed at each position had traditionally been achieved by exposing a variety of peptide sequences to the enzyme and assessing the ability of each new sequence to act as a substrate. This process required access to peptides of appropriate sequence variability, and these peptides were usually obtained by serial chemical synthesis and purification. Another challenge associated with the characterization of substrate selectivity is the establishment of a facile assay procedure by which the products of protease action may be detected, identified, and characterized. Again, this process can involve resource-intensive serial purification of each product in the incubation followed by its characterization. Remembering the pin methodology described by Geysen, I thought we could overcome the limitations of these methods by the design and reduction-to-practice of a new technology for the characterization of substrate selectivity. This technology would focus on the chemical synthesis and enzymologic evaluation of large numbers of peptides, which were attached to a solid-phase matrix: in other words, an “immobilized peptide array”!

A cornerstone of our strategy was that the action of the protease on the immobilized substrate would release an easily detected species into the solution phase, which could then be readily separated from the solid phase and quantified. When we initiated our studies on this problem, there were no examples in the literature of the interaction of proteases with potential substrate sequences that were immobilized by attachment to a solid phase. Our first goal was to investigate the consequence of this attachment. We chose the metalloprotease thermolysin and a known solution-phase substrate sequence PLALF for this enzyme for our initial study (Figure 21). Teruna Siahaan prepared the N-protected pentapeptide Fmoc-PLALF and coupled samples of it to *N,N*-dimethylethylenediamine and CH-Sepharose 4b. Mark Ator then incubated these materials with thermolysin under appropriate conditions and obtained the expected Fmoc-PLA-OH as the only fluorescent product, showing that immobilized peptide sequences could act as substrates for proteases.

Our next goal was to select a more appropriate solid phase for the technology. This material had to be compatible with both the chemistry of solid-phase peptide synthesis and with enzymology in aqueous media. We knew that the sequence PLALF was not a substrate for thermolysin when attached to the polystyrene resins typically used for solid-phase

“Alanine Scan” on GPLALF with Cl-t and St-t

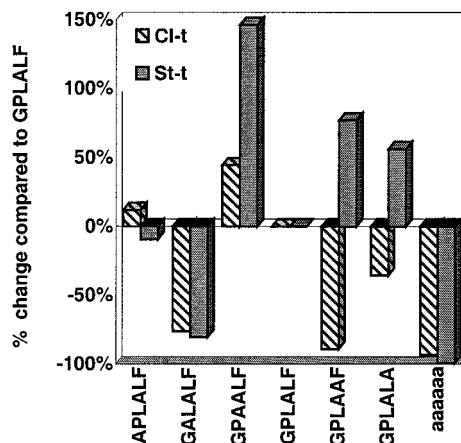

Figure 22. Effect of alanine substitution on immobilized peptide substrate GPLALF on digestion with truncated recombinant collagenase (Cl-t) and stromelysin (St-t).

peptide synthesis, and that Sepharose was not compatible with the organic media employed in solid-phase peptide synthesis. In contrast, controlled pore glass functionalized with an aminopropyl group (AMP) “anchor” (CPG) seemed to possess the required properties and had additional advantages that will be elaborated on later. Unlike CH-Sepharose 4b, CPG did not have a preformed “linker” to allow free access for the protease by positioning the potential substrate sequence away from the glass surface, so we decided to include a linker of six aminocaproic acid (Acp) moieties. CPG has been used for the solid-phase synthesis of polynucleotides, but its use for solid-phase peptide synthesis has not been extensive. Nevertheless, we were able to efficiently assemble Fmoc-PLALF(Acp)₆AMPCPG using typical solid-phase peptide synthesis methods, and we were pleased to find that the CPG conjugate released the expected fragment (Fmoc-PLA-OH) on agitation with thermolysin.

During these studies we found that the Fmoc group was not suitable for our purposes, due to its base sensitivity. After evaluating a number of potential marker species Tom Gordon found that the 7-hydroxycoumarin-4-propionoyl group (Cop) was an excellent marker group. At this time, we also systematically investigated the influence of (Acp)_n-based linkers on thermolysin substrates. We chose to look at peptide sequences containing both lipophilic and hydrophilic residues and found that optimal linker length is at 7–8 Acps and appeared to be independent of sequence. We also found that substrate activity decayed at longer linker lengths. We hypothesized that this might be due to partial envelopment of the peptide sequence into the relatively hydrophobic linker “molten globule” at higher Acp lengths. An alternative hypothesis that the CPG pore became too “filled” with immobilized peptide at longer linker lengths to allow access of enzyme seemed less plausible.

Having established the feasibility of immobilized peptides as protease substrates for the relatively well-known enzyme thermolysin, our next objective was to use the technology to investigate the substrate selectivity of more physiologically relevant enzymes. The first “application” goal chosen for our new technology was to identify selective substrates for

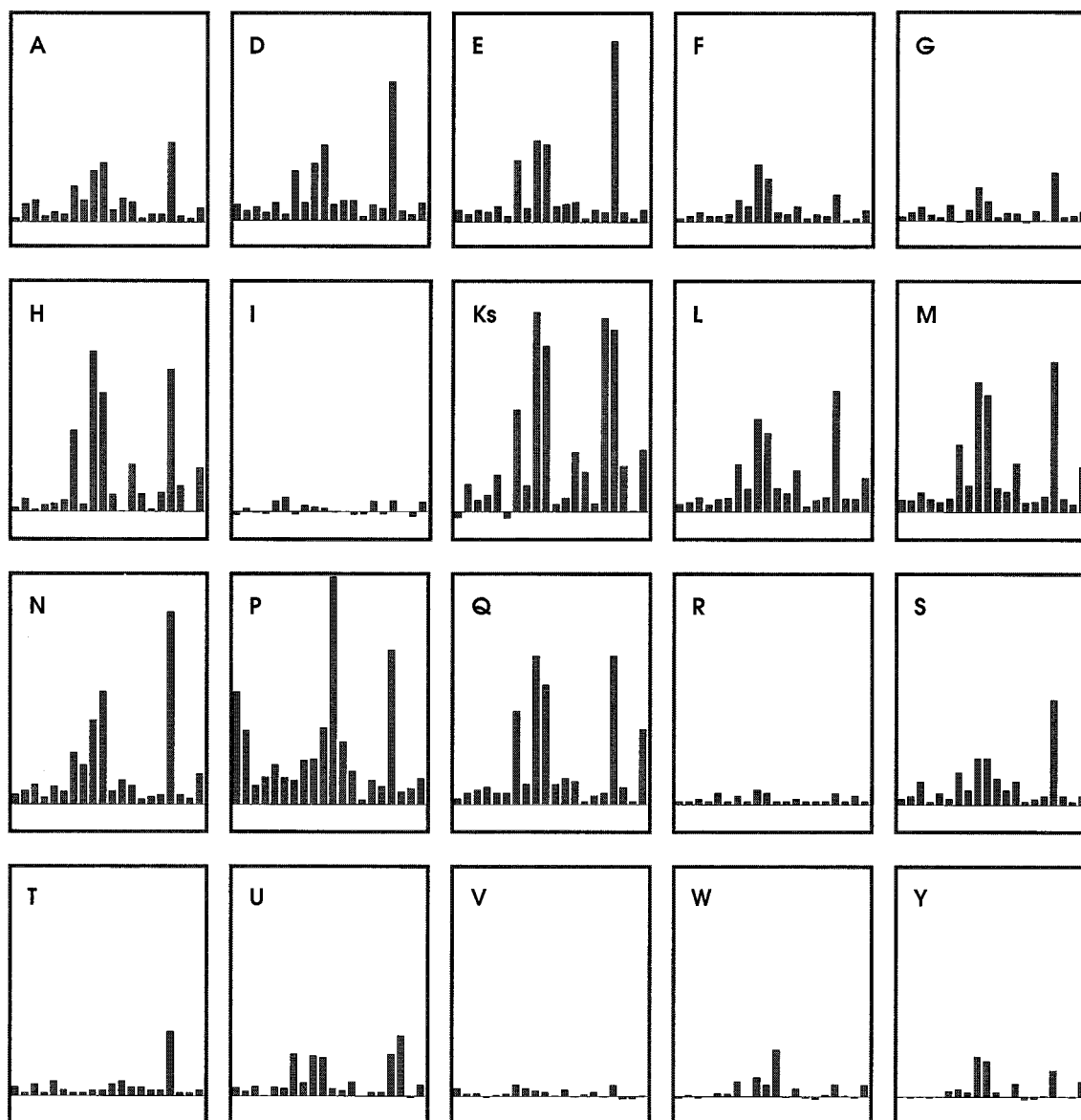

Figure 23. Data for mCl-t digestion with volume AAXAXBA from library. The amino acid at the first X position names the set, e.g., the “T-set”, lower row, first panel, refers to AATAAXBA. The second X position is defined by the tube in the set, for example, the first tube in the T-set is AATAABA.

the matrix-metalloproteases collagenase and stromelysin. Initial experiments with “truncated” recombinant collagenase mCl-t and stromelysin mSl-t2 using Cop-GPLAMF yielded time-dependent data only when either BSA or Triton was added to the incubation medium to reduce nonspecific binding of the enzyme to the glass surface.

Our next goal was to develop a strategy for high-throughput synthesis using combinatorial methodologies. We were interested in developing what we termed an “alanine matrix” approach to substrate mapping. In this approach we planned to synthesize the initial peptide probes in a “window” within an alanine matrix “frame”. Thus, in the construct Cop-A-A-X-X-X-A-A-(Acp)₆-Amp-Cpg, the sequence A-A-X-X-X-A-A is a heptapeptide alanine frame encompassing an X-X-X tripeptide window. To determine the size of the frame and the size and design of the window, we carried out “alanine scans” on the known collagenase substrate GPLA-LF. In addition we included a hexa D-Ala sequence as a “negative control”. The enzyme data for these peptides are

shown in Figure 22. The P3 proline residue was crucial for substrate activity with both mCl-t and mSl-t2 while the P1’ leucine was necessary only for mCl-t. The P2 L → A substitution resulted in a “better” substrate with both enzymes, while alanine substitution at P4 glycine or P3’ leucine was tolerated by each enzyme. Note that the a₆ negative control served its purpose well. With this information in hand, it was clear that a P-X-X-L sequence was necessary for mCl-t to recognize a substrate. These data confirmed our plan to construct the following three-volume library

Cop-A-A-X-A-X-B-A-(Acp)₆-Amp-CPG

Cop-A-A-X-X-A-B-A-(Acp)₆-Amp-CPG

Cop-A-A-A-X-X-B-A-(Acp)₆-Amp-CPG

in which X was a position where we incorporated a serial cassette of 20 amino acids singly in 20 tubes. The amino acids used were the 20 coded amino acids with *S*-methyl

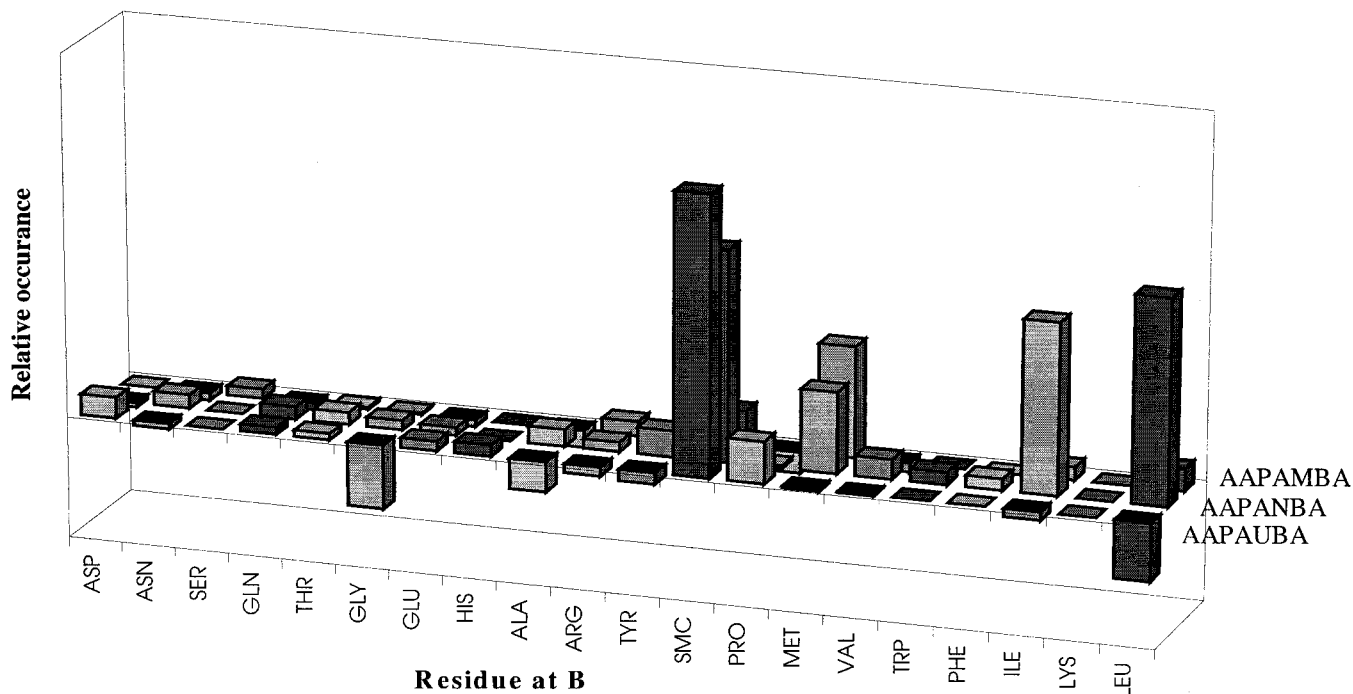

Figure 24. Identity of active sequences in the B position was achieved by sequencing the unprotected peptides on the glass “revealed” by the enzyme. The B breakout in the first cycle of sequencing for all three volumes is shown.

cysteine (U) substituted for cysteine. B is a position where the 20-amino acid cassette was incorporated as an equimolar mixture in a single tube via the protocol first outlined by Furka¹⁴⁸ and his collaborators. Thus each volume consisted of 400 tubes (a 20 × 20 matrix), each tube containing 20 sequences degenerate at B.

The first volume to be investigated was A-A-X-A-X-B-A. The library was assembled by Tom Gordon and Jim Gainor in five racks, each rack composed of 80 tubes containing 1600 sequences, plus positive and negative controls. The rapid sedimentation rate of CPG compared to polystyrene supports decreased the synthesis cycle time significantly. The data for mCl-t with this volume (AAX-AXBA) is shown in Figure 23. The amino acid at the first X position names the set, e.g., the “T set” refers to AATAAXBA. The second X position is defined by the tube in the set, for example the first tube in the T set is AATAAABA.

Note the similarities between the A, D, E, F, G, H, K, L, M, N, Q, U, and Y sets at the AAXAXBA position, with the AAXAXBA preference for all these sets being U > L > M > I ≫ all others. Clearly the P set was different, with N > U > A > D = M = P. The other sets (I, R, T, and V) were essentially too weakly active for analysis.

The identity of active sequences in the B position was achieved by sequencing the unprotected peptides on the glass “revealed” by the enzyme. The B breakout in the first cycle of sequencing is shown in Figure 24. B breakout of the AAPANBA tube shows that, of selected active tubes from the AAPAXBA set, the “activity” of this tube is due largely to four residues U > L > I > M and that one cycle of sequencing gives an unambiguous result. Breakout of this tube by synthesis of the individual components and enzymologic evaluation confirmed the same four active sequences with essentially the same relative activity. B breakout of

AAPA(M,U)BA differs from the above cases in that there is essentially a single residue in the first cycle of sequencing. In these cases the site of cleavage is not resolved unambiguously by the first cycle of sequencing, as cleavage could be at the A-(M,U) position, or the (M,U)-(B=M,B=U) position. This ambiguity was resolved by the second sequencing cycle, which showed that for both the AAPA(M,U)BA tubes cleavage occurs predominantly at the A-(M,U) position. The identification of this frame shift, in which the potential for a M or U residue to occupy a P1' position can override the dominance of a P3 directing P residue, relegating it to P2 position, is an example of the power of the technology in teasing apart the complexities of protease substrate selectivity.¹⁴⁹ Jasbir Singh later validated these results by comparison with k_{cat}/K_m data for a set of soluble substrates.¹⁵⁰

By this time we had developed robotic procedures for most of the operations of the technology. The libraries were assembled on a pair of ACT MPS 350 multiple synthesizers, and, with the help of Marty Echols and Jim Koch, the enzymology, including sample weighing, was being transferred to an Orca robotic workbench. Automated sample labeling and data analysis was planned. Unfortunately, premature termination of the project due to the dissolution of Sterling Drug in the spring of 1994 did not allow further application of the technology to other proteases.

In addition to the scientists named in this perspective, I would like to acknowledge the contributions of Marty Allen, Stephanie Beigel, Tim Dankanich, Carla Gilliam, Rosita Olsen, James Solowiej, Adi Treasurywalla, Rob Wahl, and Dave Whipple to this work.

Surfaces Modified for Synthesis and Arrays

D.H. comments: Much insight into the development of array technology can be gleaned from the contribution concerning the photolithographic processes developed at



Figure 25. Mario Geysen's group; photo around a campfire at Mario's mountain hideaway, standing (from left to right) Richard Lauricella, Stuart Rodda, Andrew Bray, Mario Geysen, Gordon Tribbick, John Wang, and Joe Maeji.

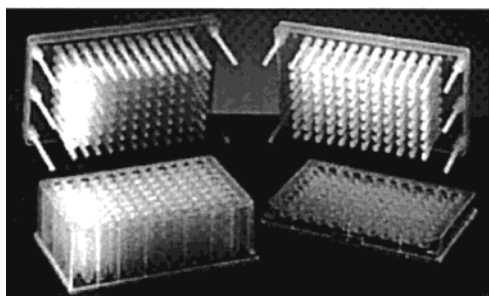

Figure 26. Early form of multipin device: two blocks of pins and reaction trays.

Affymax. The publication of this research in *Science*, with an attention-grabbing color display on the front cover, was the single most influential paper which convinced people that technology would revolutionize synthesis. Paul Hoeplich¹⁵¹ tells an inside story on what it took to develop the photolabile Nvoc protection to be suitable for this idea (another example of striking gold in the mother load of the old literature). As Paul relates, the technology has evolved into a form remarkably useful in diagnostic applications, as with the DNA arrays.

The seminal work which has fueled much of the array technology, was, of course, that of Mario Geysen, who realized the power of the 96-well microtiter plate format and elected to use synthesis on pins mounted on a block which fitted this format.¹⁵² The development of the method and the surface modification chemistry is described by Stuart Rodda and Joe Maeji. See Figures 25 and 26 for the Geysen group and an early form of the Geysen pin method.¹⁵³

I am happy to be able to bring to your attention the little known work of Brian Clark¹⁵⁴ who took on the task of modifying chemistry so that synthesis and assay could actually be performed on the well surfaces of polystyrene microtiter plates. This idea involved mild nitration and reduction to the anilino form and synthesis, as I recall, using solvents which did not craze the polymer, DMSO being one such selection. The idea of surface coating PE/PTFE of course stems back to the very early work of Geoff Tregear, which has seen a resurgence of interest in the development of polymer-coated tubes, by IRORI (which is described by

Chanfeng Zhao), and likewise with beads and balls (Paramatrix, a company which appeared to have had a very brief existence).

Paul D. Hoeplich, Jr.¹⁵⁵ Synthesis on Glass Surfaces: The Affymax Arrays

"...and after we have synthesized large mixtures of peptides, we will probe the collection with the affinity matrix and extract the source of a given biological activity", so said Alex Zaffaroni, or something quite similar, in the boardroom of ALZA during a rainy November evening in 1988. Michael Pirrung, then at Stanford, had invited me to meet with Zaffaroni and described our recent work, at Triton Biosciences, with the Geysen "pin-method" of simultaneous peptide synthesis. This was my first encounter with the fabled pharmaceutical maven, and he lived up to every expectation. The evening session turned out to be not only an initial interview for a position in a new start-up company called Affymax NV but a wide ranging discussion about the potential of an impending shortage of new drug lead candidates. Actually the discussion was more focused on the pace of discovering these sorts of compounds. By the end of the month, certainly before Christmas, I had signed on as the first laboratory scientist—to head a group in peptide chemistry.

What struck me as somewhat odd at the time was the notion that we were going to intentionally make mixtures of compounds; this concept is the antithesis of "classical" training in organic synthesis wherein one tries to design reaction protocols that achieve maximal yield and purity. Now, to be challenged to make mixtures of compounds (peptides) took me a while to appreciate and accept. But as we all know now, Zaffaroni's vision was several years ahead of its time and did portend the way things were to go.

The central question became how do we make collections of molecules that can be systematically interrogated? A few months into 1989 with a few more people on board including Ron Barrett and Steve Fodor we began looking at photolithographic approaches to preparing large populations of small organic molecules. Leighton Read, in particular, along with Pete Schultz, Mike Pirrung, and the rest of the burgeoning scientific crew must be credited collectively for this unique insight.¹⁵⁶ Parenthetically, the acronym VLSIPS (very large scale immobilized polymer synthesis) was inspired by the VLSI corporation name; Read's neighbor in Palo Alto, as I recall, worked there! In any event, how to demonstrate simultaneous synthesis of a large number of molecules (peptides) utilizing a photocleavable protecting group on the α -amino group was the essence of the synthetic strategy. We considered several photolabile protecting groups but it became clear that the Nvoc group showed the greatest promise.¹⁵⁷ The idea that I developed was to functionalize a glass cover slip surface with triethoxy amino propyl silane and build the peptide molecules, drawing on earlier work by Art Robinson and his replication of Merrifield solid-phase peptide synthesis on glass beads.¹⁵⁸ The glass surfaces were "dip coated" in a solution of 2% (w/v) 3-aminopropyltri-

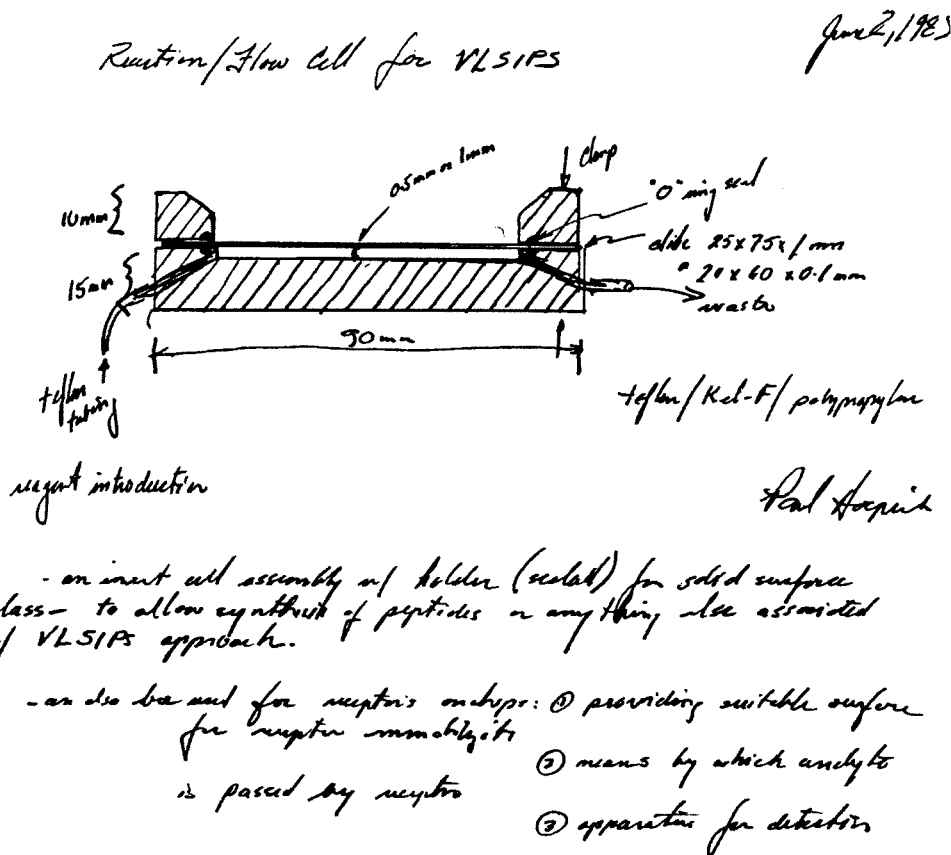

Figure 27. Original sketch, dated June 2, 1989, made by Paul Hoepfich of the flow through reactor used in the Affymax photolithographic method.

ethoxy silane/EtOH for 2 min at room temperature, rinsed with both EtOH and water, and then heated in vacuo for 2 h at 100 °C, effecting a stabilized silyl ether cross-linked network.

The key embodiment for the successful implementation turned out to be a flow cell. I drew/sketched the first ideas during a plane flight back from visiting scientists at Sandoz in Basel (Figure 27). Using the flow cell, the first Nvoc-amino acid was bound to the surface, via the immobilized amino silane, by pumping a solution of amino acid, HOBt, and uronium salt in DMF. After a short coupling time, excess reagent was simply pumped out/displaced by a bolus of neat solvent. The Nvoc group was removed by exposure of the glass surface to light while pumping DMF solution and an amine or thiol through the cell to scavenge/quench the nitroso aldehyde derivative formed and released through *hv*-mediated deprotection. The newly exposed α -amino was available for the addition of another Nvoc-protected amino acid; the cycle repeated until the desired sequence was assembled. The peptides were synthesized in an “upside down” manner relative to the functionalized glass surface, i.e., synthesis occurred on the surface with the direction of chain extension being into the cavity of the flow cell. Details of the first flow cell and glass surface are shown in the sketch (Figure 27)—note the date, over 10 years ago! I cannot remember the name of the machinist who took this image and fabricated the flow cell, but I recall that he was head of Syntex’s machine shop. I gave him a single drawing on a Friday afternoon and I had three devices the following Monday morning!

Lubert Stryer, on leave from Stanford, developed an algorithm that utilized a variety of orientations of a single simple mask permitting irradiation (Nvoc removal) of selected areas. This clever approach allowed for selective and sequential “photolithographic” exposure of spots on the surface to light (actually the underneath side of the glass cover slip once immobilized in the flow cell), permitting the simultaneous synthesis of spatially separated groupings of peptides. Differential mask orientation facilitated selected surface irradiation and the free amino group so exposed was used in peptide bond formation. Repetition of the cycle of mask orientation/reorientation, irradiation, and coupling resulted in “libraries”, spatially distinct groupings of peptides on the glass surface housed in the flow cell. These libraries of peptides were then “developed” by exposing the surface, again by the use of the flow cell, to a fluorophore-tagged molecular recognition element (MRE), like a monoclonal antibody, and the image/pattern was recorded.¹⁵⁹

Basically, the same paradigm exists today for creating arrays of molecules, usually DNA oligomers, on a variety of surfaces; although glass, I believe, is still the preferred substrate. These DNA arrays are “read” by adding a fluorophore-tagged DNA oligomer “probe”, introduced as the MRE. Ensuing hybridizations between the probe(s) and immobilized array results in an image which is read by an optical scanning device. Present day embodiments include the Hewlett-Packard GeneArray Scanner instrument for the Affymetrix “GeneChip” technology.

Looking back over the 10 years, arrays have become a routine tool in genomics and other aspects of discovery

science that require high degrees of parallelism and throughput. At the time, it was just fun to create novel ideas, work with creative people, and address a critical problem affecting the pharmaceutical industry and, ultimately, the health and well-being of people.

Derek Hudson. The Pilot Lead Optimization and Library Technique

I was fortunate enough to make a very minor contribution to array and library synthesis during my time at Arris Pharmaceuticals.^{160,161} At that time there was much excitement about peptide libraries and one compound one bead approaches. I immediately appreciated that in the absence of the resources required to develop a high-technology equivalent, simple physical barriers could be used to construct arrays¹⁶² if the channel block was rotated through 90°. ¹⁶³ A second critical factor was a close relationship with Selectide. In the early days assays were continually plagued with false positives arising from the ancillary reagents used

in the enzyme linked assays. I reasoned that direct fluorescent or radio labeling would largely be devoid of such effects, and as the Pilot method was configured, no signal amplification would be required even when rather weak binding affinities were involved. I particularly liked the idea that Pilot plates could form the books of a library, which could be interrogated initially and then returned to "the stacks", as in a real library, for subsequent reacquaintance. Many promising but deficient supports were investigated, notably pepsyn K particles glued in position and wells filled with thin polymeric films (see Figure 28, right),¹⁶⁴ but the real breakthrough came with Arris' acquisition of a Pharmacia Biacore instrument for determining binding constants and kinetics. This system embodies an elegant chemistry consisting of a dextran layer, within which lead compounds are anchored and displayed, attached to a gold surface by means of a linker bearing a thiol group which coordinates with the Au atoms. I immediately realized that PE surfaces could be functionalized with dextran in the manner shown in Figure

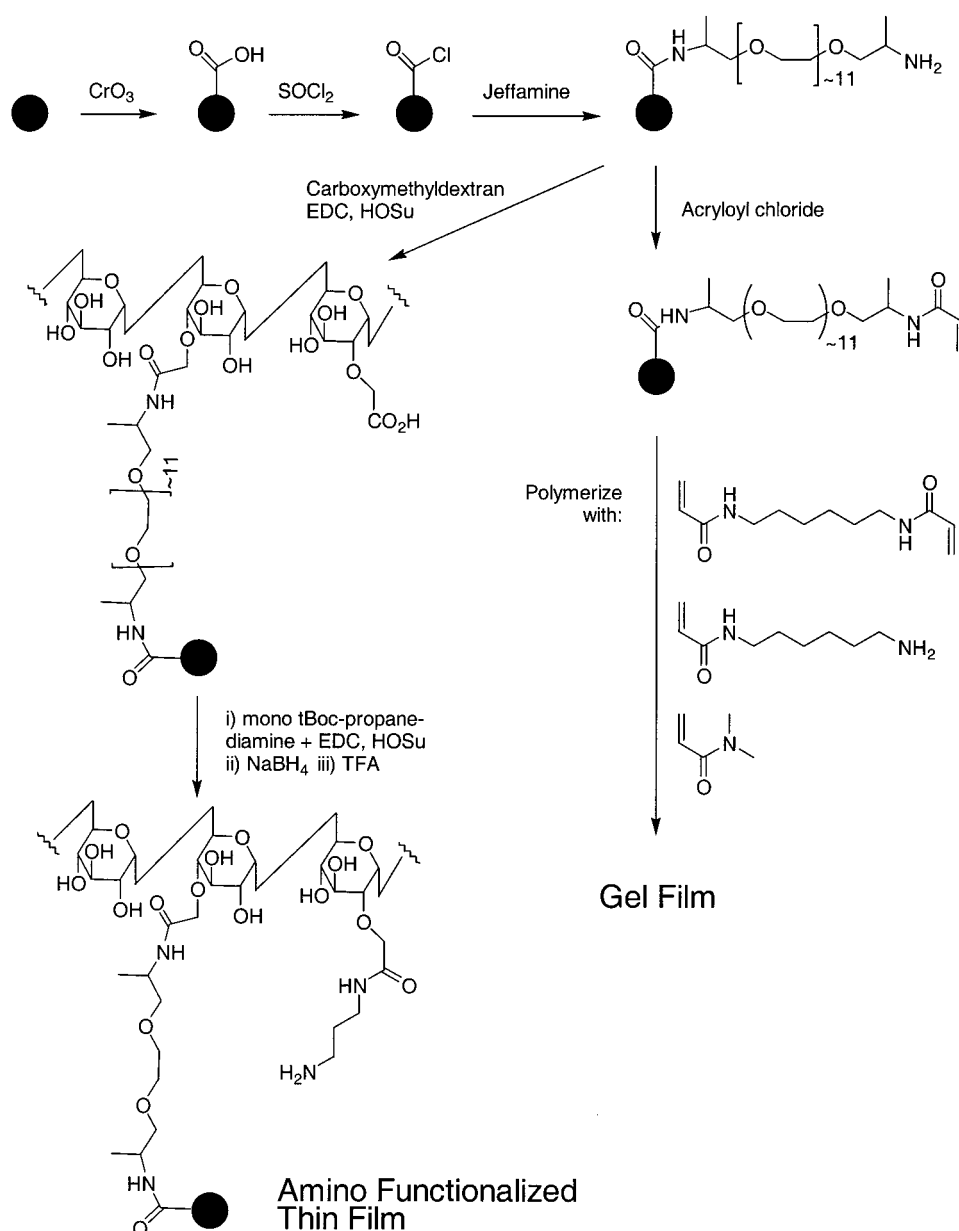

Figure 28. Chemistry used to derivatize PE surfaces for the Pilot lead optimization and library method.

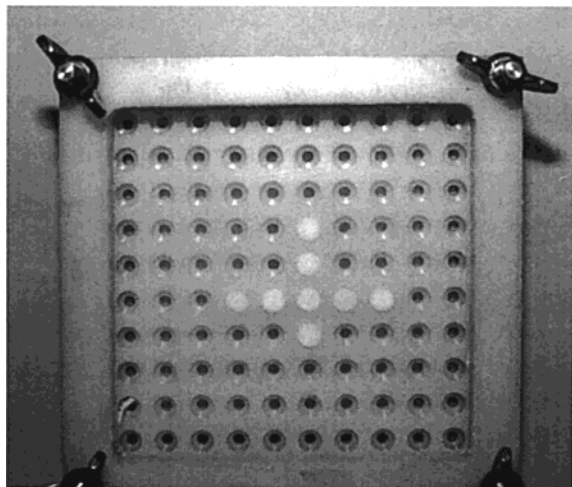

Figure 29. Probing chamber and array plate holding porous dextran-coated PE disks (“tiddly winks”) in Pilot technique.

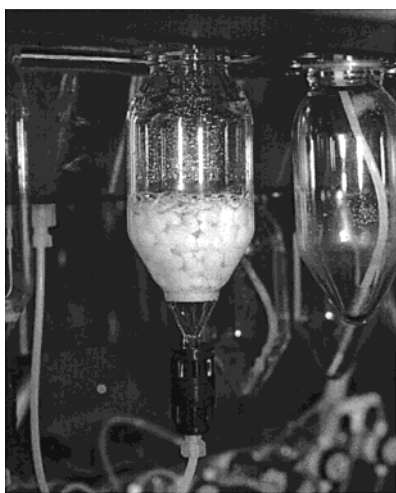

Figure 30. Pilot disks being processed in reaction vessel of a Milligen/Biosearch model 9600 synthesizer.

28. This construct closely mimics that of the BiaCore technique, by providing a highly hydrophilic framework, ensuring display in an environment close to those found naturally. A final component of the invention was the realization that each area of the array could actually be a detachable porous polyethylene disk and be mounted in a flow through block, thereby providing rapid high-efficiency washing (Figure 29). A bonus provided by the application of these “tiddly-winks” was that common sequences could be constructed in a conventional peptide synthesizer reaction vessel (Figure 30), and libraries on libraries were much facilitated. The method worked very well for determination of the 3E7 antibody binding specificity, exactly mimicking the results found with other library techniques, as well as working out the specificity of a tyrosine kinase, but gave less clear results in other cases. I found the fact that solution- and surface-bound binding affinities could frequently differ by very large amounts to be fascinating, but others at Arris did not have that perspective; it took more painstaking work by Joe Buettner and Rob Harris (of Commonwealth Biotechnology, Richmond, VA), as we have seen, to gain insight into how this occurs and to develop a practical application of this phenomenon.

Stuart Rodda.¹⁶⁵ Origins of the Multipin Method

Mario Geysen was the primary originator and inspiration behind the Multipin method of peptide synthesis.^{166,167} A Foot and Mouth virus project took him to The Netherlands in 1982, where he came up with the idea of mass parallel synthesis while taking his compulsory daily shower in the staff decontamination rooms of the secure Foot and Mouth Vaccine facility of the Dutch Veterinary Institute. With aid from his Dutch collaborators and people at his home institute, the Commonwealth Serum Laboratories (CSL) in Melbourne, Australia, he set out to prove that parallel synthesis of thousands of peptides was an achievable aim. His early efforts were by synthesis on glass; but when he was alerted to the technology of radiation-grafting of otherwise inert polymers such as polyethylene, the Multipin method using molded plastics was born.

The work might have stopped there, or might have taken a completely different path, were it not for a chance meeting between Mario and a senior CSL executive in the men’s bathroom during a refuelling stop at Bahrain airport on the long flight from Europe to Australia. The men, previously unaware that they were travelling “home” on the same aircraft, sat together for the rest of the flight, and Mario unfolded his vision for an epitope mapping project leading to a new generation of peptide diagnostics and vaccines. With executive support at CSL now established, a project team was assembled and “Project X” began.

My involvement started in 1983 with Mario and Tom Mason; our mission was to get Multipin synthesis going at CSL as quickly as possible. I spent a month at the Dutch Veterinary Institute; my memories of that time include the achievement of epitope scans through two viral proteins and an awful lot of cycling through the Dutch countryside on Mario’s “executive bicycle”.

The project at CSL went well at times, and at other times we were desperate because peptide synthesis simply did not work on a particular batch of grafted pins. While trying to understand the factors which affect the quality of peptide synthesis on grafted pins, Mario and I performed a “synthesis challenge” where we both made a set of peptides, using our favorite conditions (solvents, reaction times, number of washes, etc.). To my great disappointment, the results were a “dead heat” wherein both sets of peptides performed well and we had not established the superiority of one method over another; the main consolation was that it showed that the synthesis method was fairly robust and one did not need to be an experienced bench chemist to achieve valuable results with peptides!

Memorable also was that, in those heady days when we were testing many peptide-related ideas, including the concept of peptide libraries¹⁶⁸ and the resulting “mimotopes”,¹⁶⁹ we had a culture of friendly challenge, to push the champion of an idea to defend and prove his/her idea. To make the challenge more meaningful, it was obligatory to bet “a chocolate cake” on the idea: if the critical experiment disproved the concept, the loser would be obliged to supply a chocolate cake large enough to feed everyone in the lab. This was powerful motivation indeed not to fail, especially for those who, in the event of a loss, would be

forced to beg their spouse to cook the cake. Conversely, success usually meant the opening of a bottle of champagne during an afternoon tea break, a practice best performed on a day when no further lab work was required and one could work quietly on writing up results until the effects of the celebratory spirits had worn off.

In later years, the large scale of an experiment was rarely used as an excuse for not tackling a difficult problem. It was not uncommon for a synthesis of 1200 solution-phase peptides to be tested on the blood cells of 10 or more donors, each test being carried out with multiple replicates.¹⁷⁰

Looking back, I am struck with the fact that, scientifically, all cards were always on the table, i.e., nothing was taken for granted and everything was subject to challenge and verification by experiment, a true characteristic of the scientific approach to expanding our understanding of nature. Over-reliance on dogma can stultify ideas and prevent new discoveries; Mario was never one to rely on dogma.

Joe Maeji,¹⁷¹ Recollection: Combinatorial Chemistry in Mario Geysen's Group, Melbourne, Australia

I cannot talk about the real beginnings of the Multipin method and the Mimotopes (combinatorial libraries) project as I was not there in 1982 when it all began. They are for Mario Geysen and others who were actually involved in the invention of the "Multipin" method to present. My recollections begin in 1987 and focus on some of the chemistry activities of Mario's group.¹⁷² At that time, peptide synthesis by the Multipin method was by Boc chemistry.¹⁷³ There was no method of cleaving the peptides from the "pins" and there were no adequate analytical techniques to assess quality of synthesis. The overriding emphasis was biological readout as the redundancy inherent in the ability to make so many peptides gave sufficiently good internal controls. Peptide purity was not a criterion for a successful synthesis. This was emphatically driven home to me on several occasions, with the most memorable being the first T-cell epitope study.¹⁷⁴ At the time of this study, we had not fully developed the diketopiperazine (DKP) forming linker¹⁷⁵ and, by my calculations, I thought we were lucky if we had 1 μ g of the correct peptides. However, the T-cell proliferation study was a tremendous success despite my dire warnings.

The Multipin method was a screening tool. Any interesting peptides needed to be resynthesized in larger quantities, and this was the original activity of the Chemistry section. Here, we used resins and mainly Fmoc chemistry. We had the technology to synthesize thousands of peptides, but the chemists synthesized peptides one by one. Why could we not use the Multipin method to synthesize thousands of high-quality cleaved peptides in multi-milligram quantities? For me, nearly all the chemistry activities since that time have their beginnings with this question. However, the first years were mainly occupied as a peptide service group and in building a chemistry organization in what was a vaccines company. Fortunately, I was soon joined by a number of excellent people among whom were Andrew Bray and Robert Valerio. Our laboratories were disused rooms of the original penicillin production laboratories (first for nonmilitary uses) of our parent company, Commonwealth Serum Laboratories

(CSL). I am sure many have gone through the experiences of setting up laboratories, but more unusual "highlights" from that time were cleaning possum¹⁷⁶ droppings and paw prints off lab equipment until we caught the culprit. Another example was disturbing a large bee hive in trying to improve water flow for our vacuum aspirators. Fortunately nobody got stung.

The opportunity to work on pins came with the decision to go to Fmoc chemistry and the need to develop a simultaneous cleavage method for peptides for T-cell epitope analysis. The DKP linker was our first concept for multiple simultaneous cleavages and was soon followed by base cleavage of esters¹⁷⁷ as well as gas-phase ammonolysis reactions.¹⁷⁸ In the late 1980s and early 1990s, we explored these concepts as well as intramolecular reactions that only allow cleavage of the end product, orthogonal linkers on one pin, reaction screening, and high-throughput analysis. It is amazing what a difference a few years can make, as many of these ideas were later explored and published by other groups.

The original pin support was poly(acrylic acid) grafted to polyethylene. The carboxylic acid was capped with mono Boc protected ethylenediamine (Boc-HMD) and then reacted with Boc or Fmoc- β -Ala. The β -Ala loading was set at 50 nmol as this was all that was required for screening. But the Boc-HMD loading was 1000–1500 nmol.¹⁷⁹ No matter what we did, we could not achieve efficient peptide synthesis at 1000 nmol loading. These activities were looked upon with humor by the nonchemists who did not understand why the chemists wanted to make such huge quantities. There were no practical applications for making thousands of 20–50-mer peptides in milligram quantities, and there still are not. Looking back, there was a clash of cultures between people who had great faith in the sensitivity of biological assays and others who desired higher quality and quantity of synthesis and analytical readout. I am sure this difference of opinion has been played out in many companies. However, it was known that repetitive ELISA on peptide-bound pins resulted in the loss of reaction with certain epitopes, i.e., the solid phase itself affected the assays. Regardless of the exact reasoning, we started grafting experiments in 1989 and steadily increased loading capacity of one pin to 250 nmol and then 1000 nmol and beyond. When we reached a temporary maximum, we started making bigger pins.¹⁸⁰ While we successfully grafted polystyrene, our interests were for more hydrophilic supports which led to the development of the polyhydroxyethyl methacrylate and poly(methacrylic acid/dimethylacrylamide) surfaces.¹⁸¹ These graft polymers were more suitable than poly(acrylic acid) or polystyrene for peptides and the complementary aqueous-based cleavage methods we were developing. By 1993, we had the capability to simultaneously synthesize >3000 peptides in multi-milligram quantities. This was the basis from which we developed a custom peptide business for which Chiron Technologies is known. I think the longest peptide we synthesized (and sold) was a 64-mer, and the pin looked like it was covered in jelly. We also developed alternatives to the acrylic acid grafted support used for epitope mapping,

but its importance decreased with the ability to make larger quantities of peptide for solution-phase competition ELISA.

In 1992, CSL sold the group to Chiron Corporation, and a year later Mario left to further develop his ideas at Glaxo. While differences of opinion (mixtures vs single compounds) remained, the main research focus became single compound small molecule synthesis. At this time, the hype on large mixture libraries was probably at its maximum. The key question was whether the greater quality assurance and quantity of each compound in making smaller numbers of single compounds (<5000) compensated for the power of sheer numbers. The other question was whether we could have enough understanding of the fundamentals in solid-phase chemistry to achieve predictability of synthesis outcome whether one was synthesizing one or a thousand compounds. The jury is still out, especially for the latter, but we are optimistic. Compared to where we started, the latest "crowns" have now achieved over a 1000-fold increase in loading and with higher reaction rates. The Multipin method still exists, but more and more it is about modular designs and specific shapes for particular applications. It is about an alternative solid phase that is now comparable to some resins, and the technology is getting better. It also has certain advantages, e.g., the grafting process allows one to isolate the variables of polymer type, cross-linking, size/thickness, and loading. With resins, this is not possible so there is still a lot of interesting science left to do.

Acknowledgment. After returning from Japan in 1987, I was looking for a job. I was feeling lucky as there were a number of options, but one easily stood out. It was not the job itself but an individual. In retrospect, I did not realize how lucky I was. After that first meeting, the following five years with Mario Geysen were the most stimulating time in my scientific career so far. I would like to take this opportunity to acknowledge and thank Mario. Also, my acknowledgments go to Andrew Bray and Robert Valerio. The chemistry outcome was a collegiate effort of these key individuals, and it was fun working in a completely new field.

ChanFeng Zhao.¹⁸² A Perceptive Look at the Development of MicroTubes for Solid-Phase Synthesis

Introduction. This article presents a brief review on MicroTube developments and applications based on the author's experiences. A new solid support for organic synthesis has been developed by radiation-grafting polystyrene onto inert polymer tubes (such as polypropylene or a fluoropolymer; 5 mm o.d. \times 18 mm length, see Figure 31). The grafted tubes have been functionalized with a wide range of reactive groups and utilized in a variety of solid-phase organic reactions. Rather than using individual beads, MicroTubes containing inserted radio frequency tags can be used in the "directed sorting" library methodology to obtain multi-milligram amounts of discrete compounds.

From Idea to Product. I graduated from the group of Professor P. N. Prasad of the State University of New York at Buffalo, with training in polymer and fluorescent dye synthesis. I learned for the first time about "combinatorial chemistry" when I joined IRORI (a five-month-old company

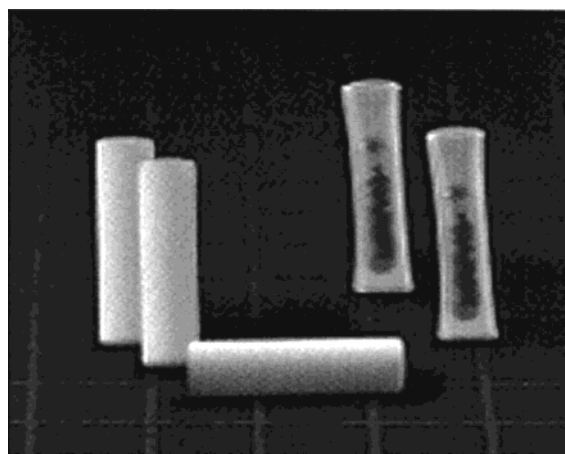

Figure 31. Early forms of IRORI MicroTubes.

with four employees) in October 1995. I first set out to create a polymer coating with chemical functionality attached directly onto the Radiofrequency¹⁸³ Tag (3 mm o.d. \times 12 mm length), so that the Rf tag could be used for solid-phase synthesis directly. The Rf tag is protected with a glass housing to prevent the electronic device from contacting organic solvents. The method we first tried was, of course, to attach 3-aminopropyl trimethoxysilane onto the glass surface; the silane monomer would react with OH groups on the surface and polymerize in situ to functionalize the surface. Many other polymerizable monomers were also tested. However, the highest loadings obtained were only in the nanomole range. Rather predictably, this proved the biggest limitation of this coating method.

At the end of 1995 and during early 1996, my extensive reading on related literatures^{184–187} paid off. In addition, I discussed on a daily basis many ideas with Dr. Xiao-Yi Xiao (who already had more than two years working experience in the combinatorial chemistry field). We were especially intrigued by the referenced book *Graft Copolymers* by Battaerd and Tregear. The authors reported that, using a radiation-grafting method, polystyrene (PS) could be attached onto other polymer surfaces and that the PS layer swelled in nonpolar organic solvents (an important characteristic for solid-phase synthesis supports). The book was published in 1972, so the knowledge of radiation-grafting had been in the public domain for over 20 years; therefore, IRORI could use this technique without infringing other people's patents. Since the Rf tag is a cylinder, polymer tubes with a slightly bigger i.d. (3.5–4 mm) could be used to hold the tag. A ⁶⁰Co radiation facility was identified; PP tubes were purchased and cut into 20 mm lengths using a razor blade; the tubes were immersed into a mixture of styrene and MeOH and sent for irradiation. After a week, I received the irradiated sample back. I found that the whole reaction had set solid; but, to my surprise, I was able to wash away excess polystyrene, which had not been covalently bonded to the PP surface. At this time, IRORI was also developing the MicroKan reactor (a meshed container which can hold loose resin), so "MicroTube" seemed to be a perfect companion name.

I will not go into the development in detail (I used to say, however, that I have many gray hairs because of Micro-

Tubes). Two important facts kept us going forward: many chemists (both inside IRORI and outside customers) were and still are willing to try the MicroTubes. I really thank them for their encouragement, especially those early MicroTube customers who got our first generation MicroTubes. In 1996, Shuhao Shi, at IRORI, made a 432 compound typhostin library using MicroTubes. It was IRORI's biggest combinatorial library at that time.

During our development program, we also tested different materials. We had chosen PP tubes because (a) the material was quite reactive toward radiation-grafting and (b) it was relatively easy to fabricate. However, even though PP MicroTubes are very useful for most solid-phase synthesis reactions, they do dissolve in nonpolar solvents such as benzene or toluene at elevated temperature (over 70 °C). PTFE or ETFE are among the most chemical and thermal stable polymers, but they are less reactive toward radiation-grafting. Fortunately, over the time period of PP MicroTube research and development, we learned to increase the PS loading onto fluoropolymers by a method that was not known previously.¹⁸⁸

The Performance and Application of MicroTubes. The polystyrene was aminomethylated¹⁸⁹ using the Tscherniac-Einhorn reaction¹⁹⁰ followed by hydrazinolysis. The amine loading was 35 $\mu\text{mol}/\text{tube}$. A variety of different linkers were coupled onto the tubes through the amine, and milligram amounts of products were obtained from a variety of solid-phase organic reactions. The purity of the products were comparable to those found with conventional resins. Reactions on MicroTubes can be easily monitored using IR. A small piece of tube sample (1 mm \times 1 mm, cut off from the end using a razor blade) gives an IR spectrum similar to that from a resin sample (ATR-FTIR spectrometer). Over time, chemists at IRORI (now ChemRx) studied over 27 different reactions using MicroTubes.^{191–195}

By controlling the radiation grafting conditions, different amounts of PS could be grafted onto the MicroTube surfaces. However, even though we were able to graft more than 80 mg of PS per tube, the optimal maximum loading was about 35 $\mu\text{mol}/\text{tube}$. Ongoing projects involve reaction kinetic studies on MicroTubes compared with commercial resins. Sometimes the reaction is faster on tubes (such as an esterification reaction),¹⁹⁶ and sometimes reactions are slower on the tubes.

On the basis of my experiences with MicroTubes and many other solid-phase resin supports, I truly believe that "Solid-Phase Synthesis Supports Are Like Solvents".¹⁹⁷ In this article, Anthony Czarnik suggests the following cardinal rule: "Optimize SPOS reactions on exactly the same support on which you plan to make the Library". Needless to say, when a chemist uses MicroTubes for a new reaction, they should optimize the reaction conditions to ensure the reaction goes to completion.

Synthesis Coupled to Screening? A Potential Application. Synthesis coupled to screening is a strategy that marries synthesis and screening on a common platform. When poly-(acrylic acid) is radiation-grafted onto MicroTubes, the resulting surface has the sturdiness and required functionality for combinatorial library synthesis, as well as providing

suitable characteristics for detecting ligand/receptor or substrate/enzyme interactions in aqueous solutions. In this assay, the MicroTubes are pooled into a single vessel and incubated with labeled acceptor molecules. After washing off nonbound materials, any MicroTube containing ligands that bind the acceptor are identified. We validated this approach by evaluating the interaction of biotin and its analogues with ¹²⁵I streptavidin. When biotin was attached to the solid support, an over 100-fold signal/background was obtained.^{198,199}

The Future. Looking back on how the MicroTube started and developed over the last three years has been fascinating for me. I believe our new support, the MicroTube, has many advantages over conventional resin supports. Clearly we still need to understand much more about the science and the relationship of the surface structure to reactivity. Synthesis coupled to screening on MicroTubes with Rf tags, or with other new grafted formats (e.g., the NanoDisk, which includes a 2-D barcode), will permit simultaneous screening of libraries prepared via combinatorial synthesis.²⁰⁰

Michal Lebl.²⁰¹ Sooner or Later Someone Else Will Cotton On to This Idea

Introduction. Nobody remembered when my Ph.D. advisor, colleague, and friend, Dr. Karel Jost, took his last vacation. He was always in the lab, synthesizing new analogues of neurohypophysial hormones. The only acceptable technique for the synthesis was the classical liquid-phase synthesis (we were actually just about the only laboratory using the Nps protection for stepwise synthesis of peptides—a very convenient protecting group, as we always knew where our bright yellow product was on the TLC or glass column). The solid-phase technique was out of the question—it would generate impure products. After long discussions, we sort of agreed that after an efficient technique for purification had been discovered, we might consider looking into the solid-phase synthesis again. The objective of my Ph.D. thesis was to prepare three rationally designed oxytocin carba analogues. I made 50, but still everything was synthesized in solution, and purified by counter-current distribution (a beautiful instrument, in which 20 mg of peptide eventually ended up in liters of *sec*-butanol/water, and one purification could take several weeks) and by gel filtration. When the first liquid chromatographs became commercially available, it was obvious that it would take too long before we would be able to afford our own instrument. After all, it was Prague, Czechoslovakia, 1978, and the price of the instrument was equivalent to the lifetime salary of the average scientist. But I needed the experiment to prove that HPLC could purify a synthetic peptide efficiently and therefore I could try solid-phase synthesis. I borrowed components from several colleagues in different institutions and assembled my first HPLC instrument. Even though the first experiments were very promising (and eventually got published), Dr. Jost was still not convinced. Then, it happened. He took 2 days of vacation! However, he cut it short and returned the next day to work. So there was Merrifield's shaker on the bench in his lab, and the coupling was in progress. I will never forget his face—but

what he said made a lot of sense: “Well, it is obvious that you will not give up on this solid-phase idea. Why don’t you go and learn it in some lab where they know what they are doing.” This was how I ended up as a post doc in Victor Hruby’s laboratory in Tucson.

Victor was great. He would let me try crazy things—for example, to cyclize peptides on the resin. This was at the time when the general feeling was that this was nonsense, and that we would get mostly polymeric material. He let me run HPLC at the freezing point of the mobile phase to separate the conformers, or study and interpret tiny differences in chemical shifts of cyclic peptides, or synthesize carba analogues of cyclic disulfide analogues of linear peptides, or synthesize oxytocin in one afternoon to settle a bet (the longest coupling was 7 min).

I was always fascinated by the potential speed of solid-phase synthesis, but it was always one compound at a time. However, back in Prague, Richard Houghten visited our lab, and we learned about “tea-bag” synthesis²⁰² directly from “the horse’s mouth”. Since that visit I tried to think how to prepare large numbers of peptides simultaneously and, of course, as we were still in Czechoslovakia, about how to make them cheaply. It was in one of these discussions with Jutta Eichler (a visiting scientist from Berlin who came to Prague to analyze her peptides prepared on cellulose paper) and Vladimir Gut (one of the most “unorthodox” peptide chemists I know²⁰³) when we started to speculate about synthesis on something cheap, plentiful, pure, durable... and we decided to try our lab coats. It worked! The substitution was low, but we ended up with a product that did not look bad at all. We were looking around for a while for alternatives such as chitin (synthesis on lyophilized cockroaches, for example), wool, or silk (silk is not the cheapest carrier, but we were in a rush), but nothing seemed to beat the cotton in terms of convenience and price. Synthesis on cotton became the topic of the thesis (started in Prague and finished at Selectide in Tucson, AZ) of my Ph.D. student, Alena Stierandova.²⁰⁴ It was vigorously pursued by Jutta Eichler during her stays in our laboratory in Prague, back in Berlin, and later at the Torrey Pines Institute for Molecular Studies in San Diego. The final contribution to the evaluation of cotton from the Prague laboratory was the Ph.D. thesis of Marketa Rinnova, who attempted the synthesis of an analogue of HIV protease by fragment condensation on cotton.²⁰⁵

Cotton in General: Chemistry. Cotton is the purest form of cellulose. Cellulose powder was one of the first carriers tested (and found not satisfactory) by Bruce Merrifield²⁰⁶ in his search for an optimal solid support. Cellulose paper was used by Ronald Frank for the parallel synthesis of oligonucleotides²⁰⁷ and, later, peptides.²⁰⁸ Paper was also used for the so-called “SPOT” synthesis, where the activated amino acids are spotted onto the predetermined locations on the cellulose sheet, and the assembled peptides are tested by exposing the whole sheet to the respective target solution.²⁰⁹ This technique spread into several laboratories, and it is commercialized by Jerini Biotools.²¹⁰ However, paper still has the basic disadvantage of its mechanical instability—multiple synthesis can be achieved only by arranging the

paper pieces into columns and passing the solutions through them. Combining paper pieces in a shaken vessel results in a very interesting mess (library on fibers—we did not find any use for this stuff).

Cotton is a polysaccharide with a high content of free hydroxyl groups, which, potentially, could be used for the attachment of the first amino acid. However, the highly crystalline character of cotton does not allow the hydroxyl groups to be modified easily—cotton must be treated to decrease its crystallinity and expose the hydroxyl groups. We have found a convenient method to improve OH accessibility: simple treatment with trifluoroacetic acid. Such pretreated cotton can be substituted to the level of 0.25 mmol/g, which we considered satisfactory for most applications in solid-phase synthesis.²¹¹

Direct attachment of the first amino acid to cotton results in the formation of side products during the cleavage from the support by aqueous hydroxide solutions. The impurities were characterized and found to be peptides bound to saccharide units. Therefore, we decided to attach the first amino acid (typically glycine) directly to the cotton only as a handle onto which a suitable linker was coupled. As a catalyst for forming the ester bond we have used (dimethylamino)pyridine or *N*-methylimidazole. Alternatively, we tested subtilisin-catalyzed transesterification of cotton—with not much success. Ester bonds with OH groups of cellulose are not completely stable under the conditions of peptide synthesis: treatment with 20% piperidine in DMF representing 18 steps of the synthesis resulted in loss of 6% of the peptide; treatment with 25% TFA (12 cycles of synthesis) resulted in 9% peptide loss. To improve the stability, we tested modification of cotton by trichlorotriazine, followed by nitroaniline coupling and reduction of the nitro group.²¹² The results were not very encouraging, but I believe that trichlorotriazine treatment followed by diamine coupling is the best way to modify cotton for the synthesis. A convenient way of detaching peptides directly coupled to cotton is ammonolysis by gaseous ammonia.²¹³

A very comprehensive study of cotton as a synthetic carrier is available only from Ph.D. theses.^{204,214} This study covers alternative attachments of amino acids to cotton (cyanogen bromide treatment, reaction with 4-fluorobenzenesulfonyl chloride, periodate oxidation followed by reductive amination, epichlorohydrin treatment followed by ethylenediamine coupling), coupling methods (based on the difficult sequence ACP_{65–74}, DIC/HOBt method was found optimal), protecting group (Boc/Bzl vs Fmoc/But), or linker strategies (basic, acidic, safety-catch, diketopiperazine based). Cotton performance was tested on other difficult sequences: polyalanines, β -sheet forming structures, or “leucine-zippers”. Cyclization on cotton was tested both on disulfide and lactam containing cyclic peptides.

It should be noted that cotton has some peculiar properties, which should be taken into consideration in the synthesis. Some peptide sequences have a high affinity toward cotton, and it is difficult to extract them from the carrier.²¹⁵ On the other hand, the high content of hydrogen bond donors and acceptors may prevent self-association of the growing peptide chain. The synthesis of deca-alanine, which is known to

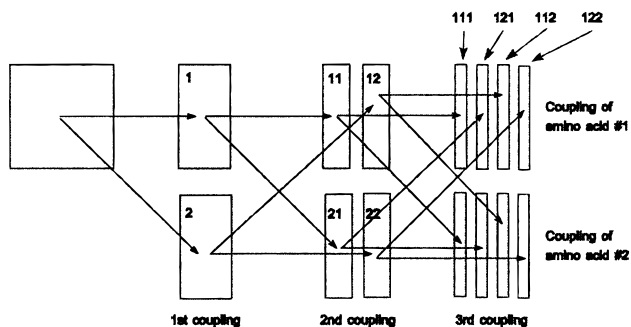

Figure 32. Principle of building the library with only one representation of each structure. In this example two building blocks were used in three steps resulting in eight compounds (on eight pieces of cotton).

proceed with a great difficulties after the fifth or sixth coupling, did not show any difficulties when performed on cotton (however, the product was very hard to extract).²¹⁶ Cotton can also act as a scavenger, preventing the transfer of side chain protecting groups from arginine to tryptophan.²¹⁷

Attractive Properties of Cotton. The most attractive features of cotton as a solid-phase synthetic support are found in its shape and mechanical properties (after it is processed into a textile-like material). Cotton can be cut into pieces exactly fitting the scale of the synthesis. Each piece can be processed very simply by transferring between steps of the synthesis using tweezers. They can be dipped into the respective solutions and dried either by squeezing them between sheets of filter paper or by centrifugation. The cotton pieces can be easily processed without filtration in any flask, just by pouring off the liquid without any risk of losing the solid support. A very convenient reactor is a polypropylene syringe—solvents are removed by squeezing the cotton piece hard by the piston. Multiple pieces of the cotton fabric can be labeled with a pencil and processed in parallel, basically the same way as the tea-bags of Houghten. We have compared tea-bags and cotton by the synthesis of 50 peptides in the same reactors.²¹⁸

Cotton has been used not only for multiple syntheses^{204,216,218,219} but also for the synthesis of libraries, both in positional scanning and iterative deconvolution formats.^{215,220} Mixtures of acetylated hexapeptides representing 2 606 420 peptides were tested for inhibition of trypsin. After the primary sequence Ac-AKIYRP-NH₂ was identified, building and screening a secondary library representing 49 521 980 peptides improved the inhibitory activity of the resulting peptide.²¹⁵

The continuous divisibility of cotton fabric allows for the synthesis in any scale as well as for the synthesis of libraries with a guaranteed representation of all possible structures.²²¹ In this case, the synthesis of the library is started with several large pieces of cotton or cotton threads. Each of these pieces is coupled with a different amino acid. After the first coupling, the pieces are subdivided and distributed for the second coupling. This process can be repeated until the mechanical limits of divisibility are reached (see Figure 32). Even though no coding is used in this case, the process provides all possible structures without any duplicities,

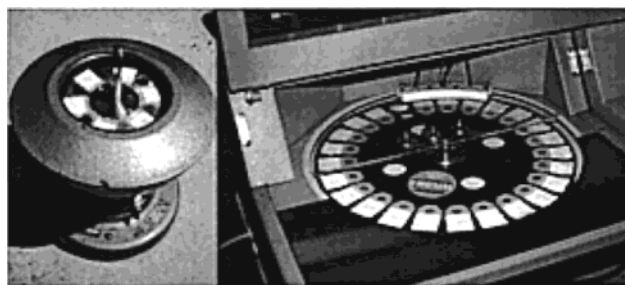

Figure 33. Laboratory centrifuge with six grooves for cotton pieces: (left) the first model of the synthesizer; (right) the rotor with 24 positions for cotton carriers.

because it does not use the statistical split and mix technique.

However, there is really no need for any reaction vessel. We have performed many syntheses just by placing a cotton strip onto a flat glass plate and soaking the reagents into the cotton fabric. Since there is no excess liquid around, it is not necessary to shake the solid support—the distribution of the active reagent by diffusion is adequate. Obviously, if the concentration of the reagent did not exceed the “concentration” of the free amino groups inside the cotton carrier, it would be impossible to achieve the complete reaction. We call this principle “inclusion volume coupling”, and we have tested it with resin-type carriers as well.^{204,222}

Technological Application of Cotton as Carrier. We have designed a multiple synthesizer which uses cotton as the carrier, and built the first prototype. Centrifugation is the first choice of everybody for the daily life chore of washing clothes; spinning efficiently removes liquid from textile fabrics! So it was obvious to use the same principle in a synthesizer using cotton fabric. Figure 33 shows the model for the test experiments—a flat grooved rotor to which the small pieces of cotton were attached, mounted on a laboratory centrifuge. Building blocks (amino acids) were pipetted onto the fabric together with the activator. Capillary forces distribute the solution evenly throughout the carrier, and the coupling proceeds without any liquid in excess of the amount that can be soaked into the carrier. A very convenient way of following the process of the coupling is bromophenol blue monitoring. The cotton is first colored with a dilute solution of bromophenol blue, then this solution is centrifuged off, but cotton remains blue if there are free amino groups available.²²³ During the coupling, actually at the very end of the coupling, the blue color disappears, indicating complete coupling. This type of monitoring is noninvasive, since no sample of the carrier has to be taken and destroyed, and is also “real time”.²²⁴ After completion of coupling, the reaction solution is removed by centrifugation, and the solvent used for washing is introduced. The washing performed in this way is very efficient, since almost all (i.e., 94%) of the liquid can be removed from the cotton fabric by centrifugation. We were able to perform the whole synthesis using just one wash between coupling and deprotection, as well as between deprotection and coupling.

Since the first experiments were successful, we built a completely automatic synthesizer capable of synthesizing 24 peptides in parallel (see Figure 34).²²⁵ This synthesizer went through several versions and was the reason for forming a

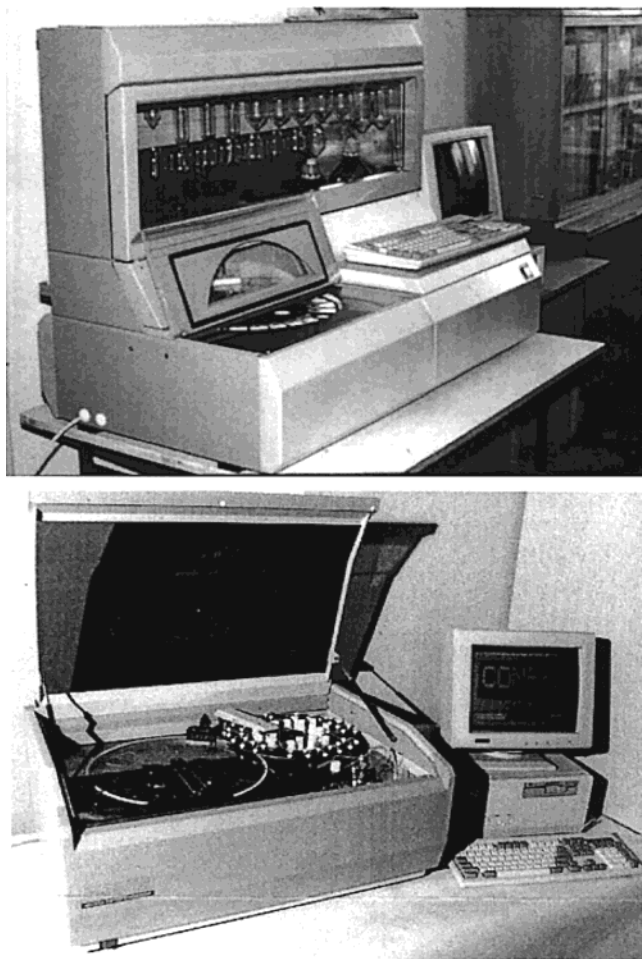

Figure 34. Two incarnations of the cotton solid-phase synthesizer. The synthesizer in top panel, Compas 24, utilizes compressed nitrogen for reagent deliveries. The instrument in the bottom panel, commercially available Compas 242 (Spyder Instruments, Inc.), uses four gear pumps for delivery of common reagents and uses gas cylinder actuated disposable piston pumps for delivery of building blocks.

company, Spyder Instruments, the goal of which was commercialization of this machine. The success of this company was rather limited; we have built five machines and sold four of them. Two of these machines were used rather heavily for several years and produced hundreds of peptides. However, 24 peptides in one run was not really a competitive number; there were several instruments capable of the same production (some of them 8 times more expensive, but there are funds available for instrumentation everywhere, aren't there?). Spyder Instruments is now developing a synthesizer based on "tilted centrifugation" of microtiterplates²²⁶ for the parallel synthesis of 768 compounds on any type of solid support. This is the number we believe cannot be matched by any other instrument at this point.

Continuity of the Cotton Carrier. There is another important property of cotton fabric as solid support—continuity. This feature was utilized for the so-called continuous solid-phase synthesis, i.e., synthesis, in which the individual steps are not separated in time, but in space. All steps are performed simultaneously on the different zones of the continuous carrier, moving slowly from one zone to

another. The principle of this idea is illustrated in Figure 35. We have modeled this principle with the synthesis of methionine enkephalin.²²⁷ This principle is very powerful in that a relatively small strip of cotton can produce an impressive amount of peptide due to the fact that all steps of the synthesis can be performed at once and continually for days and weeks. We had patented and published this process in 1986, and only much later, in 1999, Ronald Frank uncovered, to our disappointment, that a similar idea had been mentioned, but not claimed (that probably is why it did not turn up in our patent searches), in an earlier Netherland patent application²²⁸—not utilizing cotton, of course, and not even performing the conceptual experiment. The idea of continuous synthesis can be extended into multiple synthesis. Just imagine having a number of compartments with activated amino acids into which multiple cotton threads (solid carriers) are being introduced. After passing through the particular compartment, the threads go into a deprotection solution, and from there they proceed into the next activated amino acid solution. Any thread can be led through any combination of solution compartments, and therefore a large number of different peptides can be prepared at the same time. To synthesize a new peptide with this system just requires leading a new thread through the correct reaction compartment set.²²⁷

The continuity of cotton allows an interesting (ingenious) approach to the generation and screening of a combinatorial library.²²⁹ A cotton thread is coiled onto a bobbin (plastic cylinder), and the coiled cotton is separated into segments by a "glue gun"—molten paraffin wax forms a seal which prevents solutions introduced onto one segment from penetrating into the next segment. After the coupling on all segments is completed, the thread is uncoiled and recoiled on the different cylinder having a different diameter. The diameters of all the individual cylinders used are selected to create integral multiples of the length defined in the first division. (For example, if the circumference of the first cylinder was 5 in. and the segments were made 1 in. long, five different amino acids would be used in the first step. The second cylinder's circumference could be 7 in., thus creating 7 segments after rewinding. These two steps could create 35 individual peptides if 35 in. of thread were used for synthesis; however, much larger libraries can be constructed using this principle). At the end of the synthesis, each segment contains one individual peptide. On-carrier assay can be used for evaluation of the activity of all these peptides. In this case, a very simple reader can be constructed to read the response (e.g., coloration of the support after interaction with the particular target) from the continuously moving cotton thread. The structure of the particular peptide is "encoded" by its position on the thread. Since the synthesis is performed by means of a regularly repeated process, the evaluation of the result can be done by Fourier transform calculation.

Other Uses of Peptide-Cotton Assemblies. We have also fantasized about the direct use of fibers bearing synthetic biologically active peptides. Imagine wearing a T-shirt which slowly releases the peptide which makes you feel good, or repels mosquitoes, or both! Perhaps a more practical ap-

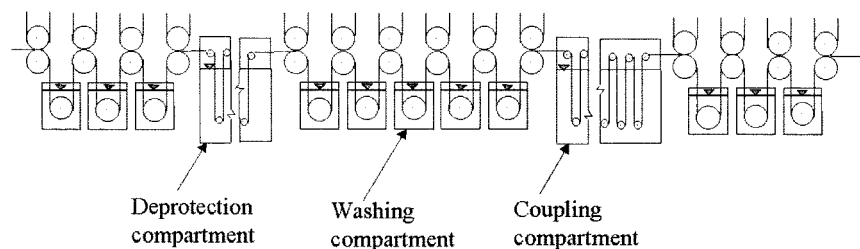

Figure 35. Principle of continuous solid-phase synthesis. The solid carrier (cotton) is being led through a series of washing compartments to a deprotection compartment and through washing to a coupling compartment. Depicted segment of the instrument allows attachment of one amino acid.

Table 10. Inhibition of *E. coli* Growth^a

	0 h	2 h	4 h	6 h
cotton with magainine	0.138	0.151	0.145	0.142
cotton without peptide	0.138	0.552	1.120	1.650

^a Measured by optical density of the media at 620 nm.

plication would be for wound healing, if an appropriate peptide (e.g., Dalargin) were to be attached onto a wound dressing fabric. We have synthesized magainin on cotton and tested this composite for blocking microbial growth. Surprisingly, it worked quite well, probably due to the slow hydrolytical release of magainin from the cotton carrier (see Table 10).²⁰⁴ Recently the idea of a cotton wound dressing with elastase inhibitors attached to it via glycine residues was tested by Edwards et al.²³⁰

Even though our early attempt to use ELISA directly on a cotton carrier failed,²¹¹ it was later shown²³¹ that libraries synthesized on cotton sheets could be easily used for finding the ligands to antibodies evaluated by classical systems based on alkaline phosphatase or horseradish peroxidase. Figure 36 shows three rounds of deconvolution of the library XO_xXO_yXX screened for binding to the antibody against the natural sequence GHRPLDK. In this case, the cotton fabric with a preprinted pattern of lines was used for the synthesis, and the sheets, after the ELISA test, were directly copied on a Xerox machine.²⁰⁵ In another study, direct ELISA on cotton was compared with a competitive ELISA for the recognition of a known antigenic determinant by the respective monoclonal antibody. Competitive ELISA was more successful in finding the correct sequence, while direct

ELISA found the correct amino acid in the positional scanning format only for one position, and a deconvolution approach had to be used to identify the correct amino acids for the other positions of the sequence.^{220a}

Cotton can be solubilized by treatment with highly concentrated solutions of LiCl in organic solvents or by strong acids. We have tested cotton solubilized in 1 M methanesulfonic acid in TFA in ultrasonic bath and reprecipitated it in water, resulting in a fine powder. Such peptide-cotton conjugates, as well as peptide-cotton disks, were used for immunizations, either by injection or by direct implantation in rabbits.²¹²

This short summary of what was done or what might be done with cotton as a solid support (but, in general, with any textile-like material) should stimulate the reader's creativity and remove traditional ways of thinking about types and shapes of materials available for the solid-phase synthesis. An ideal solid support would actually disappear at the end of the synthesis (this is not fantasy any more—Ball et al.²³² have shown that a polymeric support can be created from a monomer, which is actually one of the building blocks in the synthesis, and at the end the total destruction of the polymer leads to the desired compound). Cotton does not disappear, but on the other hand it is so inexpensive, that its persistence is almost unnoticeable. I believe that textile-like materials have a promising future in the synthetic applications and that cotton will play a reasonable role in these developments.

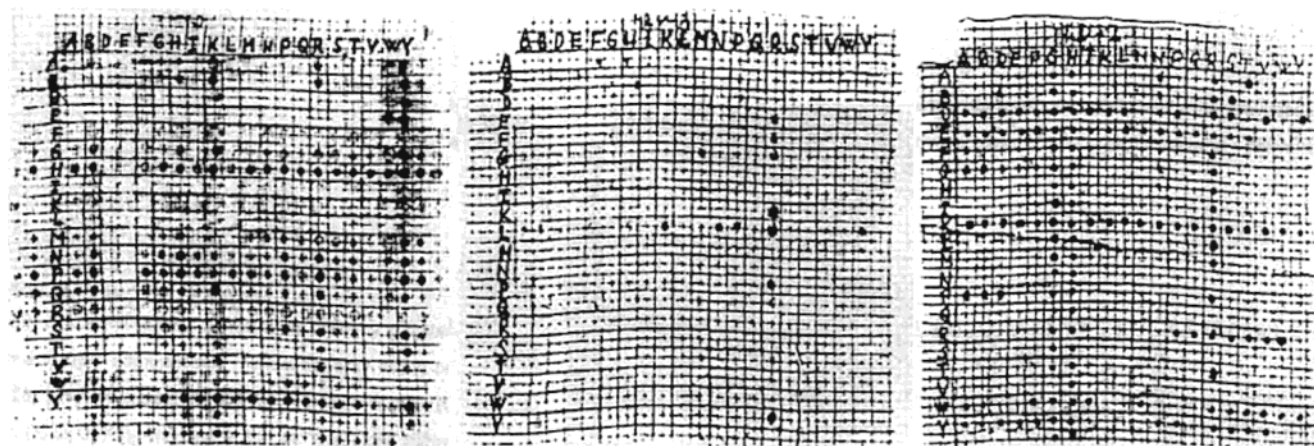

Figure 36. Three rounds of deconvolution of the library XO_xXO_yXX screened for binding to the antibody against the natural sequence GHRPLDK. The libraries (from the left): XO_xXO_yXX , XHO_xPO_yX , and O_xHRPLO_y . Dark spots mark interactions with the antibody and x and y coordinates define amino acid responsible for the binding.

Scott B. Daniels.²³³ Polymeric Membranes as Solid Supports for the Synthesis of Biomolecules

For many years, particulate materials have been used as supports for the solid-phase synthesis of biomolecules. The synthesis of peptides has been performed mainly on polystyrene-based resins, and the synthesis of oligonucleotides has been predominantly performed on controlled pore glass (CPG). The use of these particulate supports, along with advances in chemistries and instrumentation, continue to produce products of increasing purity, complexity, and size.

Polymeric membranes are relative newcomers as solid supports for synthesis and have certain advantages over particulate solid supports. Their merits include mechanical stability, minimal swelling in synthesis solvents, controlled porosity, and high internal surface area-to-weight ratio. A membrane support can allow for sufficient functionalization of the surface for the synthesis and cleavage of a peptide or oligonucleotide product. In contrast to a conventional beaded support, a sheet of porous contiguous polymer lends itself more easily to rapid simultaneous synthesis of large numbers of targets, miniaturization of automated devices, and novel reactor designs. Additionally, membranes are most suitable for small scale applications where the product remains covalently attached to the support. This synthesis format allows for some unique applications, such as affinity purification, epitope mapping, diagnostic devices, and covalent sequence analysis.

Polymeric membranes perform efficiently in the synthesis of peptides.^{234–238} The initial support was a derivatized poly(vinylidene difluoride) membrane.²³⁵ Although the use of this membrane support resulted in the synthesis of pure peptide products, it became fragile after long exposure to the synthesis solvents. Subsequently, polypropylene was found to be much more stable as a base material for peptide synthesis.²³⁴ The polypropylene membrane was treated with a solution of aminoethyl methacrylate (AEMA) and tetraethylene glycol diacrylate (TEGDA) to coat it with amine functionality. The small pore size ($0.2\ \mu\text{m}$) of the membrane provided a very large surface area ($24\ \text{m}^2/\text{g}$) that resulted in a substitution level of 300–500 nmol of amine/cm² (see Figure 37). This membrane was further functionalized with a spacer followed by the racemization free attachment of a fluorenylmethoxycarbonyl (Fmoc)-protected amino acid linker to produce the peptide synthesis membrane.²³⁹ The final loading of the Fmoc-amino acid on the membrane was approximately 0.1 mmol/g.

To use this membrane as a solid support on a continuous flow peptide synthesizer, it was necessary to pack the membrane in a column or device such that the synthesis solutions could access the entire membrane surface. Any configuration in which the solution was required to pass through the membrane (i.e., stacked disks or radial flow through a membrane roll) resulted in prohibitively high operating pressures. To provide a less restrictive path for the flow of solvents and reagents, a nonwoven polypropylene mesh was laminated to the membrane. This membrane/

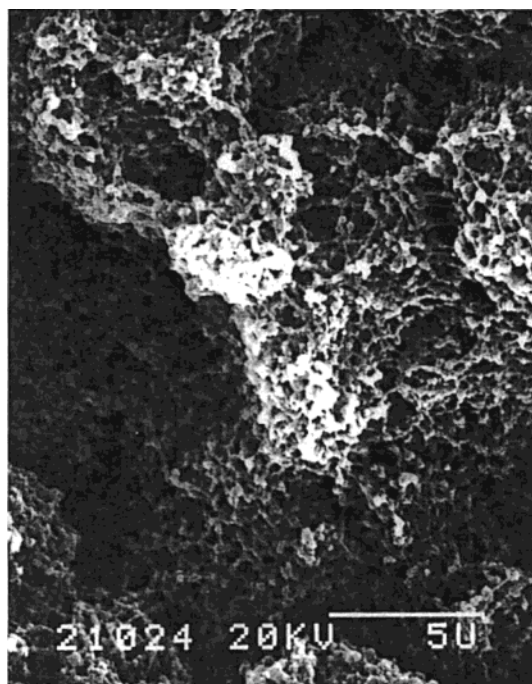

Figure 37. SEM image of a cross-section of a polypropylene membrane (at $\times 5000$ magnification).

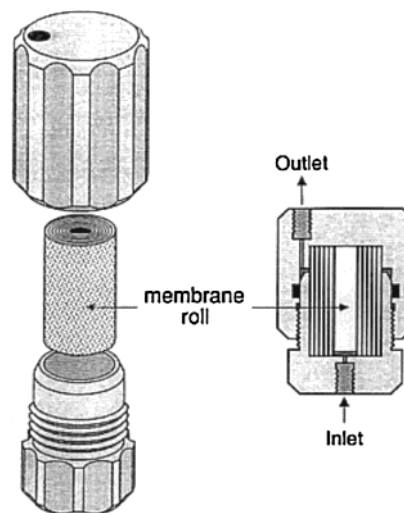

Figure 38. Flow through reactor vessel for a membrane-based peptide synthesizer showing rolled membrane and details of the flow geometry.

nonwoven composite was rolled and inserted into a column of a continuous flow synthesizer. In this configuration, the efficiency of the washing was low, so relatively large amounts of solvent were required to produce high-quality peptides.

A cartridge was designed, using the same membrane/nonwoven roll that would direct the flow of solvents and reagents evenly past all surfaces of the membrane (see Figure 38). The membrane roll was inserted into the cartridge, and the top and bottom of the membrane roll were compressed against the ends of the cartridge. The flow of solutions was directed into the middle of the membrane roll and flowed through the nonwoven material spiraling toward the outside of the roll where the cartridge outlet was located. This design resulted in even wetting of the entire membrane surface.

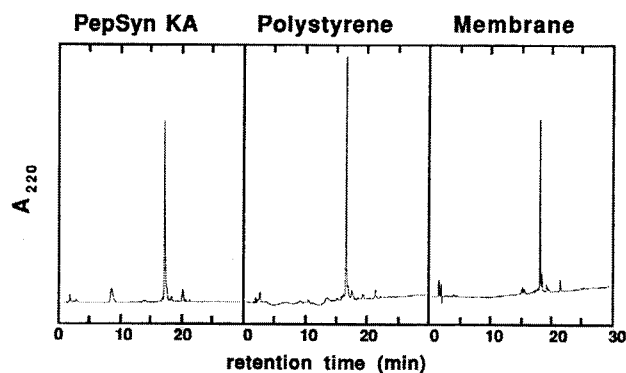

Figure 39. HPLC profiles show crude peptide products from synthesis on three alternative supports.

Diffusion through the membrane was fast so that this resulted in very efficient washing and reaction kinetics.

The performance of the membrane support and cartridge was tested by comparing the assembly of several target peptides on the polypropylene membrane and two beaded supports, PepSyn K and aminomethyl polystyrene.²³⁴ The syntheses were performed at a 0.2 mmol scale using a continuous flow peptide synthesizer with the same protocol and activation chemistry (Fmoc-amino acid pentafluorophenyl esters) for each support examined. Figure 39 shows the crude reverse-phase HPLC of one of these target peptides, FOS oncogene protein 147–172 (H-CVEQLSPEEEKRR-IRRERNKNAAA-OH), synthesized on each of the three solid supports. Amino acid analysis and mass spectral data were used to confirm the identity of the peptide. As can be seen from the HPLC data, the peptides assembled equally well on the membrane as on the beaded supports.

Polymeric membrane solid supports offer additional advantages in the synthesis of oligonucleotides. Upon treatment of the standard glass-based oligonucleotide solid support with ammonia to release the oligonucleotide and remove the protecting groups, silica and polymeric siloxanes can be released. These byproducts of the cleavage reaction can complicate the purification and analysis of the oligonucleotide. Additionally, membrane supports eliminate the possibility of introduction of particulates from the CPG columns into automated synthesizers that can damage and clog components. PTFE membranes were chosen since they are chemically inert and their hydrophobic nature prevents the adsorption of water (that would quickly react with the amidite during the synthesis). The PTFE membrane was derivatized with a polymer coating formed by the polymerization of *N,N*-dimethylacrylamide, methylene-bis-acrylamide, and aminopropylmethacrylamide.²⁴⁰ The amino-functionalized membrane was then reacted with the 3'-*O*-nitrophenylsuccinates of the 5'-DMT-protected deoxynucleosides to produce the oligonucleotide synthesis membrane with a loading of about 1.5 $\mu\text{mol}/\text{m}^2$.

Since the standard scale for oligonucleotide synthesis is typically about 1000 times lower than for peptides (0.2 μmol vs 0.2 mmol), one or two small membrane disks can be used for the synthesis. The disks can be placed in a simple holder with a luer connection at each end and attached to the oligonucleotide synthesizer. The performance of the membrane support was tested by comparing the assembly of

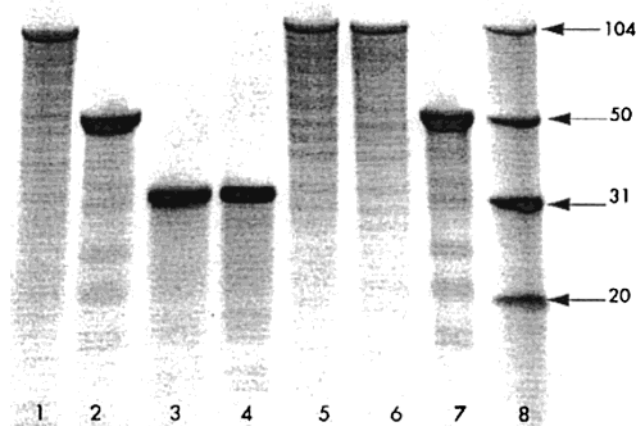

Figure 40. PAGE electrophoretic analysis of crude oligonucleotides made on membranes (4–7) and CPG (1–3).

several target oligonucleotides on the PTFE membrane and CPG. There was little difference in the quality of the oligomers between the two supports. Additionally, there is no need to select the CPG pore size based on the length of the oligomer being synthesized since the membrane is suitable for the synthesis of both long (>50 bases) and short oligomers. Figure 40 shows a polyacrylamide sizing gel of 31, 50, and 104 base oligomers that were synthesized on CPG and membrane devices.

For studying structure–function relationships in biologically active peptides, it is necessary to synthesize many analogues or overlapping segments from the biomolecule of interest. Methods for simplifying the synthesis of many peptides have been developed and include use of polypropylene pins,²⁴¹ “tea-bags”,²⁴² photolithography,²⁴³ and the multispot technique.²⁴⁴ The synthesis of multiple peptides on membranes can have some advantages over these methods in terms of simplicity of equipment, ease of use, and synthetic efficiency.

The synthesis of small quantities of multiple targets is well suited for a continuous sheet of solid support. This process can easily and economically be carried out manually or adapted for use with automated equipment.²⁴⁵ The synthesis can be performed so that after deprotection of side chain protecting groups the products remain attached to the membrane support. The entire membrane sheet can then be assayed for activity; the assay process being much simplified. Laursen and Wang describe the use of a polypropylene membrane for mapping epitopes in bovine myelin proteolipid protein (PLP) using an enzyme linked immunosorbent assay (ELISA)-type procedure.²³⁸ The peptides were synthesized on an amino-derivatized polypropylene membrane (the same base membrane described above for peptide synthesis) which was sandwiched between two metal plates. The plates had 96 holes bored in a standard microtiter plate format. The reagents and solvents were pipetted in the wells in the upper plate and removed by vacuum through the holes in the bottom plate. A series of overlapping octamers (269 peptides) corresponding to PLP (a 276 residue protein) were synthesized in about 16 h using this method. The side chain protecting groups were removed, and the membranes were probed with antisera to the intact PLP as well as specific PLP peptides to locate the epitopes. The mechanical stability

of the polypropylene membrane was important for this study since between each probing the membrane was stripped of proteins by sonication in detergent.

Although polymeric membrane supports cannot replace conventional beaded supports for the synthesis, they do offer some advantages for smaller scale and parallel synthesis. Leaving the products covalently attached to the membrane sheet permits some interesting variations. The application of membranes to combinatorial synthesis of libraries to facilitate drug research remains unexploited, but it is not without merit since highly chemically stable membranes and derivatization chemistries have been developed.

Comparison Studies

D.H. comments: I would like to express my great thanks to Bing Yan for the unenviable task of discussing this topic objectively and for drawing together various inputs and placing the topic of support comparison in an objective perspective. Nevertheless, having forseen the importance of support comparison studies many years before its time was due, I cannot resist stealing the limelight, a little, and adding some personal comments of my own.

In 1986 I was challenged by commercial needs to develop chemistry appropriate for automated Fmoc-mediated peptide synthesis. I well knew of the problems, particularly associated with the selection of the support, the poor solubility of many of the derivatives, as well as the then current concept that the use of preformed symmetrical anhydrides provided the most convenient, active, and efficient coupling method. I also realized that the concept of simultaneous synthesis, as exemplified by the tea-bag method of Richard Houghten,²⁴⁶ had the potential to glean far more *significant* comparisons than previously possible. The consideration that, with this method, the resin and reagent are not in intimate contact led me to consider performing side by side synthesis in minireactors made from macroscale DNA synthesis columns. I initiated a series of experiments to define optimal coupling conditions²⁴⁷ and synthesis supports, cleavage cocktails,²⁴⁸ appropriate protection for Asn and Gln, linkers, and many other variables. Suddenly I was inundated with significant data, a problem never previously encountered in methodological studies. The results simultaneously displaced the symmetrical anhydride method from its pre-eminent position, and introduced, in place, the simply automated BOP+HOBt method²⁴⁹ (the related HBTU/TBTU + additive method was later introduced by a competitor). Along with the associated reagent R cleavage and Tmob protection methods, developed in parallel, these studies transformed the ability of the Biosearch synthesizers to perform Fmoc-mediated syntheses. The power of this combination was demonstrated through excellent collaborations with Michael Weiss²⁵⁰ and Alan Frankel²⁵¹ on some very challenging projects, indeed. The comparison method, too, helped in the development of some new active esters.²⁵²

These original support comparison studies made clear that, not only is the efficiency of any reaction dependent on the nature of the support and reaction conditions, but it is also dependent on the specific nature of the target, so that it is really best to evaluate several different targets, not just one

specific example.²⁵³ This consideration explains why we chose to survey a wide range of transformations, including a Horner–Emmons condensation, and selected only closely similar comparison materials in a recent evaluation of spacer arm and environment effects with PS-PEG resins.⁴² We concluded that, although some physicochemical effects (i.e., resin agglomeration, PEG leakage) did influence yields and product purity, when the resins swelled well under the reaction conditions, there was no difference between properly prepared PS resins and PS-PEG's of various formulations.²⁵⁴

A recent, previously unpublished study, performed with 22 simultaneous syntheses of the peptide YNFEV-Nle-amide using single 1 h coupling and 10 min Fmoc removal steps, provides an excellent idea of the strengths and weaknesses of comparing the overall efficiency of a set of materials used in a complex series of reactions. Now I know a lot of you will leaf onward at the mere mention of the word peptide (and have already read it too many times); but, in self-defense, I have to say this is not a bad test. Progressively we see more and more biologically relevant scaffolds, of sophisticated target orientated design, being taken through synthetic processes involving scaffold construction, the removal of orthogonal protecting groups, and subsequent modification. For such applications, this test is, in fact, a good one. Moreover, our prior experience with this test sequence has frequently revealed poor performance with new "improved" supports. Note that the evaluation is based, necessarily, solely on the yield and purity of a single target product. Table 11 summarizes the results from this series, and they lead to some most remarkable conclusions.

First, a word or two about the correlation of yield and purity. In general, when any, or all, of a series of consecutive transformations proceed with poor efficiency, then the product will be obtained in neither good purity or yield. Certain specific steps, e.g., initial linker addition or the final cleavage reaction, can occur with poor efficiency, yet give rise to a high-purity product (but in bad yield). Other phenomenon can also contribute to bad yields, especially attrition of the support particles during synthesis, leading to loss through the reactor frits, which will either pass fines or become clogged in the process! All PS gel-based supports, whether they bear the adornments of variously configured PEG chains or not, performed identically and with quite remarkable efficiency. Doubtless Morten Meldal's sophisticated PEG-based resins, discussed in Part I, too, would have done equally well. The finding that a 2 mmol/g aminomethyl polystyrene, which yields over 1.6 g of cleaved product per gram of starting resin, performs so well, is, to me, quite remarkable. Equally notable is the poor performance, under these conditions, of a variety of alternatives (both established, and experimental, supports). High-loaded CPG is perhaps the worst (note highly comparable results are obtained with materials from different manufacturers). It should be born in mind that good DNA synthesis is only obtained at low loading ($\sim 20\text{--}40\ \mu\text{mol/g}$ 500–2000 Å material), typically in flow through columns or reactors lacking active agitation. The poor performance is provided both by overcrowding of the relatively low pore surface area ($\sim 35\ \text{M}^2/\text{g}$, cf. values for other materials) and mechanical attrition. It is tempting

Table 11. Comparison of Different Supports by Simultaneous Synthesis of the Hexapeptide YNFEV-Nle-amide

A: 1% Cross-Linked PS Samples				
code	resin type and supplier	initial loading (mmol/g)	product purity ^a (%)	overall yield ^a (%)
A	aminomethyl-PS (Biosearch)	1	>95	~100
B	aminomethyl-PS (Biosearch)	2	>95	~100
C	NovaGel (Calbiochem-NovaBiochem)	0.8	>95	~100
D	Champion (Biosearch)	0.4	>95	~100
E	ArgoGel (Argonaut)	0.4	>95	~100
G	TentaGel (Rapp Polymere)	0.21	>95	~100
O	2-chlorotriethyl resin ^b (Biosearch)	0.6	>95	~100
B: Rigid, Conventional Materials				
code	support type	initial loading (mmol/g)	purity ^a (%)	overall yield (%)
F	ArgoPore, 80 Å pore, 600 M ² /g surface, macroreticular PS (Argonaut)	0.74	79	12.5
R	macroreticular PS, 150 Å pore, 900 M ² /g surface (Biosearch)	0.9	78	30
S	alternative macroreticular PS, 300–600 Å pore, 500 M ² /g surface (Biosearch)	1.1	55	7
V	BioMac, 300 Å macroreticular polymethacrylate (Biosearch)	0.2	90	~100
P	high load CPG, 550 Å, 81 M ² /g (Prime Synthesis)	0.44	33	2
Q	high load CPG, 300 Å (Biosearch)	0.2	32	3
C: Rigid, Experimental Supports				
code	resin type	initial loading	HPLC purity (%)	overall yield (%)
H ^c	PE-PS	0.4 mmol/g	48	3
K	Aspect type IV, ^d ~10 M ² /g	50 μmol/g	56	52
J	Aspect type VI, ~25 M ² /g	96 μmol/g	47	25
M	Aspect V, ~30 M ² /g	92 μmol/g	77	82
T	experimental macroreticular PS, methacrylate copolymer, 1000 Å pores (Biosearch)	87 μmol/g	77	20
U	experimental macroreticular PS, methacrylate copolymer 1000 Å pores (Biosearch)	153 μmol/g	72	36

^b Used Fmoc-Nle derivatized resin. ^c For an additional sample, code I, all deblock and coupling steps were sonicated, resulting in yield and purity identical to those found in H. ^d For a further sample, code L, a lower load Aspect type IV gave somewhat better results.

to suggest, analogously, that the best macroreticular PS, R, is superior to comparably loaded F and S because of a greater surface area. The most promising alternative material is the polymethacrylate, BioMac (V), a specially formulated version of the same TosoHaas resin used both for DNA synthesis and in bead-based library methods (the Pelican method developed and described here by Joe Buettner).

As far as this test goes, then the worst alternative material is PE-PS, in which a linear PS coat has been attached to an inert PE core by radiation-grafting. With this formulation of PE-PS, simple reactions, e.g., Fmoc removal and coupling, occur at rates very similar to those provided on other supports; but clearly, the films prepared with linear polymer chains cannot expand in the same way as do standard PS gel beads, and this may result in peptide assembly becoming increasingly problematic. The failure of sonication to improve efficiency is surprising, since this tactic does assist synthesis on Geysen pins and crowns, although these bear acrylate-derived polymer films. These considerations may also apply to the use of MicroTubes, a product of IRORI, which bear a highly similar PS coat. Nevertheless, some recent reports indicate good reactivities with this system, and the swelling and permeability of the film is very dependent on polymerization conditions, so the formulation of this product may have been improved (see section by Chanfeng Zhao). Recent insight into this problem is provided by the production by

radiation-grafting, at Biosearch Technologies, of PE particles bearing substituted acrylamide polymers, on the same base PE particles (PE-PA). The performance of PE-PA is very dependent on monomer choice, irradiation conditions, and post grafting processing. With the right selection of these variables, the product PE-PA has much improved performance over our original PE-PS, comparable to that of traditional beaded materials (data not presented).

Table 11C also shows a series of Aspects, which have been refined over the course of our studies, to the version M, which is the best combination of derivatization method and spacer arm attachment chemistry so far evolved in terms of loading and product purity, while still maintaining the central characteristic, lack of any aromaticity in its formulation.

These studies clearly reflect how morphological and physicochemical considerations influence a particular support's suitability. To look more closely at this issue, it is necessary to attempt to measure reaction rates, and with this remarkable tool, a deeper level of insight is accessed. I am indebted to Bing Yan, who, with Wenbao Li, first found profound differences with this procedure, which requires great experimental rigor, and who has graciously and enthusiastically taken on the onerous task of putting the whole subject into an objective perspective.

Bing Yan.²⁵⁵ Comparison of Supports for Solid-Phase Synthesis

It seems that what I am going to present next may not accomplish what the title implies. The excuse is that there are not enough comparative studies in the literature to allow any general conclusion. However, there have been many enlightening papers reporting various aspects of solid supports in the past 20+ years. They should give us some clues on how to approach the task specified by the title.

Among all the variety of solid supports used for synthesis, I will focus on four classes of supports, which are most commonly used. They are microporous polystyrene resins cross-linked with 1–2% divinylbenzene (PS), PS-poly(ethylene glycol) graft resins (PS-PEG), macroporous PS resins cross-linked with >20% DVB, and surface-functionalized polymer supports. The PS-PEG resin category can be further divided into three subclasses: one with functionality attached to the end of linear or branched PEG spacers (TentaGel, Champion II, PEG-PS, ArgoGel), and the second with the functionality attached to the polystyrene backbone and PEG spacers are used only as modifiers (such as Champion I, NovaGel) and, the third with the PEG cross-linked.²⁵⁶

Solid-phase synthesis (SPS) does not occur on a solid phase, and use of the term MAST avoids that trap. Although syntheses on macroporous PS resins and the surface-functionalized polymers are closer to solid-phase synthesis, syntheses on microporous PS and PS-PEG resins are truly gel-phase syntheses, but the term solid-phase synthesis will still be used here for all such processes.

The main difference between solid-phase synthesis and the solution-phase synthesis is that, in the former, selective swelling and selective reagent absorption processes precede the synthesis (Figure 41). When comparing different supports in solid-phase synthesis, we cannot ignore any of the aspects of the solid-phase system, that is, swelling, absorption, kinetics, and yield.

Swelling. Chemists involved in SPS often have to deal with the phenomenon of resin swelling. The question can solvent A swell resin R is not so different from the question is liquid A miscible with liquid B? Although generic correlation has been studied,^{257,258} the easiest way to select a solvent is by experiment. The swelling behavior of resins in a wide range of solvents have been documented.^{259,260} Although there are discrepancies in these data, the general trend is similar (Figure 42).

What does swelling do to the resin? Merrifield showed that a good swelling solvent can enlarge the bead volume by 5-fold or double the bead diameter²⁶¹ (see also this Perspective, Part I). In a microporous resin, each bead can be considered as a solution volume of polymer segments. Bead swelling results in freer chain segment movement and a much better accessibility of chemical reagent. The chain mobility is inversely proportional to the extent of cross-linking.

Macroporous PS resins,²⁶² on the other hand, consist of a polymer phase and a free space (within the pores). In the presence of a solvent, the pores are filled by the liquid, and the polymer phase, too, may be swollen to a varying extent.

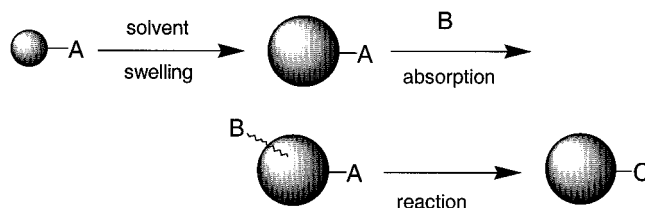

Figure 41. Steps which affect reaction rates in solid-phase synthesis.

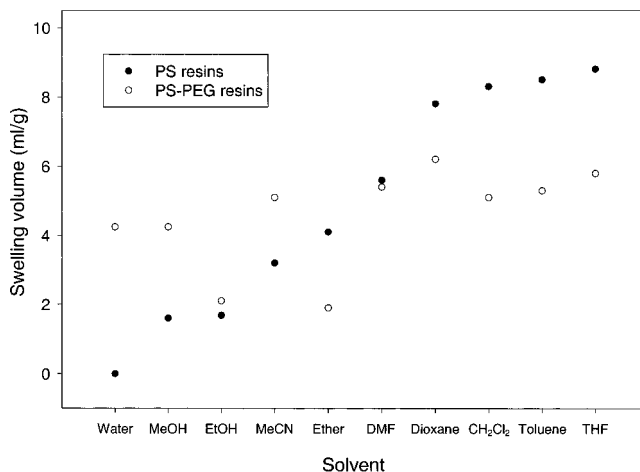

Figure 42. Swelling data for PS resins in various solvents.

The overall volume of the bead does not show enlargement. The filling of the pores is less selective for solvents, but the swelling of the polymer phase follows the same selection rule as do PS resins. The functional groups may be distributed on the surface of the pores and within the polymer phase, making the situation more complicated than for other resins.

PS-PEG resin contains a high percentage of PEG chains (40–70%), and these chains are not cross-linked (in most PS-PEG resins). These pendant segments are compatible with both polar and nonpolar solvents, due to their unique conformational flexibility (as explained by Meldal²⁶³). When resin beads are regarded as a solvent phase, the medium inside a PS-PEG resin is more polar than that inside a PS resin.

It is not known how a solvent swells a surface-functionalized polymer. However, it seems that there should be less accessibility problems for this kind of polymer. The data provided by Hudson, in his introduction, suggest that this may be true, but, for linear polymer films, problems due to chain extension seem far more significant.

In summary, macroporous resins and surface-functionalized supports do not require “swellability”, while synthesis on microporous and PS-PEG resins rely on swelling. The common trend is that PS resins swell better than PS-PEG resins in certain solvents, and PS-PEG resins swell better than PS resins in other solvents. It is even more important to note that the solvent requirement will be changing at different reaction steps. This dynamic solvation affects the reaction kinetics, yield, and the quality of the final library/product.

Absorption. A swollen bead first absorbs the reagent molecules from the surrounding medium before a solid-phase reaction occurs. Bead swelling is actually a process of

selective absorption of solvent molecules. If the reaction medium contains two kinds of species, the more solvating one will be preferably absorbed. This absorption phenomenon is as important as the swelling for SPS. The absorption coefficient²⁵⁹ of a resin for a compound relative to the solvent bulk is quite similar to the distribution coefficient of a compound between two solvent phases. If the chemical reactivity of two reagents with a solid-bound reactant is the same, then the resin absorption coefficients of these reagents determine the reaction kinetics and yield. Other factors such as steric effect and intrinsic reactivity may also come into play.²⁶⁴

Differing in polarity, the selective absorption profile of PS resins is different from that of PS-PEG resins. Two examples demonstrate that PS and PS-PEG resins are simply two different "solvent phases". One example is that a PS-PEG resin was used as a solid-phase cosolvent to facilitate the hydrolysis of 1-bromoadamantane.²⁶⁵ The second example is that similar aqueous reactions can work on microporous PS resins only when a phase-transfer catalyst was used.²⁶⁶ As for comparing their absorption ability, the nature of reagents and solvent are all-important. Kurth and co-workers have shown that the resin absorption of an electrophilic reagent $\text{Et}_2\text{O}\cdot\text{BF}_4$ is faster on PS-PEG resin than on microporous PS resin in a poor swelling solvent, and slower for PS-PEG resin in good swelling solvent for PS. Therefore, the absorption of chemical reagent can be faster on microporous PS resins than PS-PEG resins for some reagents and solvents.

Absorption by macroporous PS resin is more complicated, due to the coexistence of relatively nonselective pores and a highly selective PS phase. Again, the absorption of chemicals on surface-functionalized polymer supports should be less of a problem, in comparison.

Support Effects on Reaction. Because different solid supports possess different physicochemical, swelling, and absorption properties, the optimal support for a particular class of reactions should be selected. Many reports confirmed the need of such an optimization. Compared with the PS resins, PS-PEG resin is better suited for reactions involving water.²⁶⁷ In another case, an asymmetric alkylation of a *N*-propionylated oxazolidinone is better on PS than on PS-PEG resin, in both the reaction yield and the enantioselectivity.²⁶⁸ Macroporous PS resins have been shown to be superior to the microporous PS resins in improving the enantioselectivity in a case that both the reactant 3- β -hydroxy-5- α -cholestan-6-one and the reagent aqueous potassium borohydride are absorbed into the resin and react inside the bead to form a chiral alcohol.²⁶⁹ Comparative studies of an array of synthetic resins⁴² showed that microporous PS and PS-PEG resins are superior to macroporous resins in several peptide and organic synthesis reactions in terms of the reaction yield.²⁷⁰ In another study, the microporous PS resin was found optimal for a peptide coupling reaction compared to the macroporous PS, Kel-F-g-styrene, polyacrylamide resins, and controlled pore glass.²⁷¹

Support Effects on Kinetics. There is no doubt that SPS cannot be treated satisfactorily without reference to kinetics, which has been studied by well-established analytical

methods for peptide synthesis.²⁶¹ Nevertheless, a major challenge is provided by the kinetic study of solid-phase organic reactions. The comparison of reaction kinetics on various solid supports was previously restricted by the lack of methods for analysis. However, single bead FTIR²⁷² has proven to be a sensitive and rapid method.²⁷³ Spectrophotometric determinations have also been used.²⁷⁴ For the attachment of a Knorr linker to solid supports, reactions on PS-PEG resins (TentaGel, Champion) are faster than those on microporous PS resins.²⁷⁴ Four classes of reaction were compared on microporous PS resins and PS-PEG resins in a single bead FTIR study.²⁷⁵ The catalytic oxidation of alcohol by tetra-*n*-propylammonium perruthenate was clearly faster on PS-PEG resin, and a series of esterification reactions presented no difference on both resins. A dansylhydrazone formation and a 5-oxazolidinone ring-opening reaction with amine are faster on PS resins. These findings call for a revision of the perception that reactions on the "solution-like" PS-PEG resin are always faster than those on PS resins. The above results lead to the inescapable conclusion that an optimal reaction support depends on the reaction, and there is no such a thing as the best support for all organic reactions.

Recently, we compared reaction kinetics on macroporous PS resin, microporous PS resin, PS-PEG resin, and the surface-functionalized support. Results again supported the finding shown above.

Support Effects on Site Isolation. The isolation of the tethered reactant is a desirable property for a solid support in order to accomplish reactions impossible in solution, such as intramolecular cyclization. The surface-functionalized support and macroporous PS resins provide better site isolation effect because of the rigidity in their structure. Microporous PS resins can only isolate reactive sites when imposing steric hindrance and the lower loading. PS-PEG cannot provide site isolation.

Concluding Remarks. The similarity of a solid support to a solvent¹⁹⁷ is a valid hypothesis in the context of SPOS. It is highly desirable to carry out more comparative studies regarding various supports under various reaction conditions. From the available data, there is no doubt that supports play a profound role in determining reaction kinetics, yield, and the quality of the final library. It is necessary to optimize the solid support, solvent, and other reaction conditions for efficient solid-phase combinatorial and parallel synthesis.

Derek Hudson. Final Conclusions

All too often we live at a pace where only immediate events are in focus. I have gained considerable pleasure in the compilation of this Perspective,²⁷⁶ as indeed have my fellow contributors. It has been pleasant to have the excuse to let my thoughts return to former projects; to re-evaluate them and to realize that even more connections were involved than I had foreseen. With the generous help of all contributors, the mosaic now forms a discernible design.²⁷⁷ The image is complex; I see a first stream of materials designed for peptide synthesis, mixed intimately with a second flow of DNA-related products, with a third "new wave" component addressing the technological requirements for large numbers of products. I have found some surprising new reflections,

and I hope the reader has, too! Those who have taken on the challenge and developed this idea have done so diligently, and with great insight, as characterizes true scientists. Peptide and DNA chemists, led by Merrifield and Letsinger, rightly occupy the majority of the mosaic.

The message, which Bing Yan makes eloquently, deserves to be repeated and considered by all who practice combinatorial chemistry. The matrix is a component of the reaction and needs to be optimized for any set of transformations, just as does every other variable (e.g., temperature, solvent, concentration, reagent choice and excess, catalyst...). The tools of combinatorial chemistry give us the ability to include this extra parameter, almost effortlessly. This additional diligence will improve the fidelity of any library, so this advice has real merit. What is really needed is a systematic program to evaluate the complex interdependence of reaction type and matrix. The clues, so far uncovered by Bing Yan, Kevin Burgess, myself, and the other contributors, give some good pointers as to which support may be optimal for any application. But detailed knowledge is lacking, so prediction is impossible. Undoubtedly, the gel-type PS resins evolved by Merrifield, after detailed study of many alternatives, will prove the best selection in many cases, but others have virtues, and macroreticular methacrylates stand above other rigid beaded materials as deserving of consideration because of their demonstrated wide applicability. The beautiful new SPOCC resins of Meldal have much merit. Where assay on resin beads is important, Morten's PEGA resins, as well as gel-type dimethylacrylamides, and macroreticular methacrylates should be considered.

Since this is a Perspective, I guess I should look into my crystal ball and give some vision of the future of support development. Looking back it is quite astounding to see the enormous energy that has been thrown into this endeavor. These efforts have met with significant success; however, I would like to believe that the tools of combinatorial technology should be able to access many, many more support alternatives. These could be constructed from a wide range of inert monomers, monomer mixtures, and cross-linking reagents and produced in a range of morphologies. Might not such a program come up with products where the reactivities of attached molecules would meet or even exceed those of their solution-phase counterparts? Harbingers of this possibility might be glimpsed in my work at Biosearch Technologies where quasi-combinatorial methods have been used, both to optimize resin derivatization procedures, giving products with improved properties and reactivities, and to scan a variety of novel test materials, including the promising PE-PA particles, for potential usefulness. Elsewhere, Brocchini and co-workers have applied combinatorial methods in developing biodegradable resins^{278,279} and very recently Reynolds has used computational methods to assess further variations of this design.²⁸⁰ Clearly such approaches hold forth the prospect of providing materials with enhanced synthetic capabilities.

Neither can MAST practitioners ignore the challenge, eloquently discussed by David Sherrington in Part I, of making their technology more friendly to the environment.²⁸¹ This is no easy task, because the use of excess is usually

vital. Until high-efficiency immobilized catalysts for most reactions are available, the most practical way forward is to reduce reagent and solvent consumption. This message should perhaps be most taken to heart by those who use solid-phase techniques on industrial scales. For example, fueled by improved delivery methods, there has been a recent trend toward solid-phase synthesis of pharmaceutical scale amounts of peptides. Perhaps, polymer-coated solid-core particles, such as the PE-PA material discussed earlier, might have merit for such applications, by providing drastically reduced solvent uptake and compatibility with flow through or vapor-phase processes.

As a final word, I thank our editor, Tony Czarnik, who deserves sole credit for having had double insights: the realization that such a Perspective was needed and that I had the qualifications, integrity, patience, and latent desire for the task!

References and Notes

- (1) Hudson, D. Perspective. Matrix Assisted Synthetic Transformations: A mosaic of diverse contributions. I. The pattern emerges. *J. Comb. Chem.* **1999**, *1*, 333–360.
- (2) D.H. comments: This allusion, suggested by George Barany, refers to a quotation by Isaac Newton to Robert Hooke, "If I have seen a little further it is by standing on the shoulders of Giants." A version was revived more recently, "We are now uniquely privileged to sit side by side with the giants on whose shoulders we stand." From *A Random Walk in Science*; Weber, R. L., Ed.; Crane, Russack & Co.: New York, 1973; p 192.
- (3) D.H. comments: Many notable contributions are missing from this personal selection; either because I overlooked contacting them in the first place (most likely!), the invitation was declined, or their contribution did not arrive in time.
- (4) Department of Chemistry, Northwestern University, Evanston, IL 60208. E-mail: r-letsinger@chem.nwu.edu.
- (5) Merrifield, R. B. Solid-Phase Peptide Synthesis I. *J. Am. Chem. Soc.* **1963**, *85*, 2149–2154.
- (6) Letsinger, R. L.; Kornet, J. Popcorn Polymer as a Support in Multistep Syntheses. *J. Am. Chem. Soc.* **1963**, *85*, 3045–3046.
- (7) Michelson, A. M. *The Chemistry of Nucleosides and Nucleotides*; Academic Press: New York, 1963; p 400–443.
- (8) Khorana, H. G. *Some Recent Developments in the Chemistry of Phosphate Esters of Biological Interest*; John Wiley and Sons: New York, 1961; p 93–125.
- (9) Letsinger, R. L.; Hamilton, S. B. Organoboron Compounds. X. Popcorn Polymers and Highly Cross-Linked Vinyl Polymers Containing Boron. *J. Am. Chem. Soc.* **1959**, *81*, 3009–3012.
- (10) Letsinger, R. L.; Kornet, M. J.; Mahadevan, V.; Jerina, D. M. Reactions on Polymer Supports. *J. Am. Chem. Soc.* **1964**, *86*, 5163–5164.
- (11) Michelson, A. M.; Todd, A. R. Synthesis of a Dithymidine Dinucleotide Containing a 3'-5' Internucleotide Linkage. *J. Chem. Soc.* **1955**, 2632–2638.
- (12) Letsinger, R. L.; Mahadevan, V. Oligonucleotide Synthesis on a Polymer Support. *J. Am. Chem. Soc.* **1965**, *87*, 3526–3527.
- (13) Letsinger, R. L.; Mahadevan, V. Stepwise Synthesis of Oligodeoxyribonucleotides on an Insoluble Polymer Support. *J. Am. Chem. Soc.* **1966**, *88*, 5319–5324.
- (14) Shimidzu, T.; Letsinger, R. L. Synthesis of Deoxyguanylyldeoxyguanosine on an Insoluble Polymer Support. *J. Org. Chem.* **1968**, *33*, 708–711.
- (15) Letsinger, R. L.; Caruthers, M. H.; Jerina, D. M. Reactions of Nucleosides on Polymer Supports. Synthesis of Thymidylthymidylthymidine. *Biochemistry* **1967**, *6*, 1379–1388.
- (16) Letsinger, R. L.; Ogilvie, K. K. A Convenient Method for Stepwise Synthesis of Oligothymidylate Derivatives in Large-Scale Quantities. *J. Am. Chem. Soc.* **1967**, *89*, 4801–4803.
- (17) Letsinger, R. L.; Ogilvie, K. K. Synthesis of Oligothymidylates via Phosphotriester Intermediates. *J. Am. Chem. Soc.* **1969**, *91*, 3350–3355.

- (18) Letsinger, R. L.; Caruthers, M. H.; Miller, P. S.; Ogilvie, K. K. Oligonucleotide Syntheses Utilizing β -Benzoylpropionyl, a Blocking Group with a Trigger for Selective Cleavage. *J. Am. Chem. Soc.* **1967**, *89*, 7146–7147.
- (19) Letsinger, R. L.; Miller, P. S. Protecting Groups for Nucleosides Used in Synthesizing Oligonucleotides. *J. Am. Chem. Soc.* **1969**, *91*, 3356–3359.
- (20) For representative reviews, see: (a) Winnacker, E. L. *From Genes to Clones*; VCH Verlagsgesellschaft: Weinheim, Germany, 1987; p 53–73. (b) Uhlmann, E.; Peyman, A. Antisense Oligonucleotides: A New Therapeutic Principle. *Chem. Rev.* **1990**, *90*, 543–584. (c) Beaucage, S. L.; Iyer, R. P. Advances in the Synthesis of Oligonucleotides by the Phosphoramidite Approach. *Tetrahedron* **1992**, *48*, 2223–2310.
- (21) Letsinger, R. L.; Finnan, J. L.; Heavner, G. A.; Lunsford, W. B. Phosphite Coupling Procedure for Generating Internucleotide Links. *J. Am. Chem. Soc.* **1975**, *97*, 3278–3279.
- (22) Letsinger, R. L.; Lunsford, W. B. Synthesis of Thymidine Oligonucleotides by Phosphite Triester Intermediates. *J. Am. Chem. Soc.* **1976**, *98*, 3655–3661.
- (23) Matteucci, M. D.; Caruthers, M. H. The Synthesis of Oligodeoxypyrimidines on a Polymer Support. *Tetrahedron Lett.* **1980**, 719–722.
- (24) Matteucci, M. D.; Caruthers, M. H. Synthesis of Deoxyoligonucleotides on a Polymer Support. *J. Am. Chem. Soc.* **1981**, *103*, 3185–3191.
- (25) Ogilvie, K. K.; Nemer, M. J. Silica Gel as Solid Support in the Synthesis of Oligoribonucleotides. *Tetrahedron Lett.* **1980**, 4159–4160.
- (26) Beaucage, S. L.; Caruthers, M. H. Deoxynucleoside Phosphoramidites – A New Class of Key Intermediates for Deoxypolynucleotide Synthesis. *Tetrahedron Lett.* **1981**, 1859–1862.
- (27) Letsinger, R. L.; Heavner, G. A. Synthesis of Phosphoromonoamidate Diester Nucleotides via the Phosphite-Azide Method. *Tetrahedron Lett.*, **1975**, 147–150.
- (28) McCombie, H.; Saunders, B. C.; Stacey, G. J. Esters Containing Phosphorus. Part III. Dialkyl Iodophosphonates. *J. Chem. Soc.* **1945**, 921–922.
- (29) Tanaka, T.; Letsinger, R. L. Syringe Method for Stepwise Chemical Synthesis of Oligonucleotides. *Nucleic Acids Res.* **1982**, *10*, 3249–3260.
- (30) Pless, R. C.; Letsinger, R. L. Solid Support Synthesis of Oligothymidylates Using Phosphorochloridates and 1-Alkylimidazoles. *Nucleic Acids Res.* **1975**, 773–786.
- (31) Caruthers, M. H. Gene Synthesis Machines: DNA Chemistry and Its Uses. *Science* **1985**, *230*, 281–285.
- (32) Hunkapiller, M.; Kent, S. B. H.; Caruthers, M.; Dreyer, W.; Firea, J.; Gillin, C.; Hovath, S.; Hunkapiller; Tempst, T. P.; Hood, L. A Microchemical Facility for the Analysis and Synthesis of Genes and Proteins. *Nature* **1984**, *310*, 105.
- (33) Lipshutz, R. J.; Fodor, S. P. A.; Gingeras, T. R.; Lockhart, D. J. High-Density Synthetic Oligonucleotide Arrays. *Nat. Genet. Suppl.* **1999**, *21*, 20–24.
- (34) The acronym MAST stands for Matrix Assisted Synthetic Transformation.
- (35) LCC Engineering & Trading GmbH, Steinbruchstrasse 43, CH-4622 Egerkingen, Switzerland. Tel.: +41 (0) 62 398 52 71. Fax: +41-(0)62 398 52 74. E-mail: wglettig@tic.ch. URL: www.chemsupply.ch.
- (36) Novartis Pharma AG, K-136.4.93, CH-4002 Basel, Switzerland. Tel: +41(0)61 696 32 98. E-mail: peter.schneider@pharma.novartis.com.
- (37) Masquelin, T.; Meunier, N.; Gerber, F.; Rosse, G. Solution and Solid-Phase Synthesis of Combinatorial Libraries of Trisubstituted 1,2,5-Triazines. *Heterocycles* **1998**, *48*, 12.
- (38) Peter Schneider wishes to thank Mr. Serge Moss for his contribution by measuring and interpreting the IR and Raman spectra.
- (39) Artuso, A. *Drugs of Natural Origin: Economic and Policy Aspects of Discovery, Development and Marketing*. University of Charleston, ISBN 0-7890-0414-3.
- (40) International Forum for Combinatorial Chemistry, London, early May 1999.
- (41) D.H. comments further: Silanizing glass reaction vessels is a nasty process, at least the way I do it, in the vapor phase, and the manufacturing department was very anxious to be able to eliminate this step!
- (42) Adams, J. H.; Cook, R. M.; Hudson, D.; Jammalamadaka, V.; Lyttle, M. H.; Songster, M. F. A reinvestigation of the Preparation, Properties, and Applications of Aminomethyl and 4-methylbenzhydrylamine Polystyrene Resins. *J. Org. Chem.* **1998**, *63*, 3706–3716.
- (43) D.H. comments: Neither, it must be said, do we observe any of the strange morphologies or obvious bead to bead variations reported by Glettig for any of our beaded resin supports, be they PEGylated or not.
- (44) D.H. comments: I was equally surprised that the referees of this *J. Org. Chem.* paper were of but one mind. I quote one, “Probably the most important point that comes from the paper is something I suspected all along, i.e., that Rapp, ArgoGel and now these new alternate resins are all very similar in properties. Maybe all this hype about resins can be put to rest. This alone makes the paper worthy of publication.”
- (45) Wells, N. J.; Basso, A.; Bradley, M. Solid-Phase Dendrimer Synthesis. *BioPolymers (Pept. Sci.)* **1999**, *47*, 381–396.
- (46) Department of Chemistry, University of Minnesota, Minneapolis, MN 55455. E-mail: barany@maroon.tc.umn.edu.
- (47) As Derek admits in ref 2 of Part I, he has always had an uncanny gift of developing interesting and pithy acronyms, of which MAST, ASPECT, SAM, and HAL are but a few that come readily to mind. Nonetheless, my personal favorite remains PAL, a user-friendly name that Derek devised for the “peptide amide linker”, still the handle of choice for the synthesis of C-terminal peptide amides in concert with Fmoc chemistry. See: Albericio, F.; Kneib-Cordonier, N.; Biancalana, S.; Gera, L.; Masada, R. I.; Hudson, D.; Barany, G. Preparation and Application of the 5-(4-(9-Fluorenylmethyloxycarbonyl)aminomethyl-3,5-dimethoxyphenoxy)valeric Acid (PAL) Handle for the Solid-Phase Synthesis of C-Terminal Peptide Amides under Mild Conditions. *J. Org. Chem.* **1990**, *55*, 3730–3743, and references cited there.
- (48) With Gregg B. Fields, I co-chaired the 16th American Peptide Symposium from June 26–July 1, 1999, in my adopted hometown of Minneapolis, MN. See our web site, <http://www.chem.umn.edu/16aps/>, which will be maintained for at least a year from this writing. A permanent record of the cutting-edge science presented during this exciting week when over 1200 peptide scientists came to Minneapolis will be found in the Symposium Proceedings: *Peptides for the New Millennium: Proceedings of the 16th American Peptide Symposium*; Fields, G. B., Tam, J. P., Barany, G., Eds.; ESCOM-Kluwer Academic Publishers: Dordrecht, The Netherlands. The demands of preparing for the meeting and of tracking down loose ends upon its conclusion, prevented me from contributing to Derek’s Part I and nearly jeopardized my participation in the present Part II as well.
- (49) (a) Zalipsky, S.; Albericio, F.; Barany, G. Preparation and Use of an Aminoethyl Polyethylene Glycol-Cross-linked Polystyrene Graft Resin Support for Solid-Phase Peptide Synthesis. In *Peptides: Structure and Function, Proceedings of the Ninth American Peptide Symposium*; Deber, C. M., Hruby, V. J., Kopple, K. D., Eds.; Pierce: Rockford, IL, 1985; pp 257–260. (b) Barany, G.; Solé, N. A.; Van Abel, R. J.; Albericio, F.; Selsted, M. E. Recent Advances in Solid-Phase Peptide Synthesis. In *Innovation and Perspectives in Solid-Phase Synthesis: Peptides, Polypeptides and Oligonucleotides 1992*; Epton, R., Ed.; Intercept Limited: Andover, England, 1992; pp 29–38. (c) Zalipsky, S.; Chang, J. L.; Albericio, F.; Barany, G. Preparation and applications of poly(ethylene glycol)-polystyrene graft resin supports for solid-phase peptide synthesis. *React. Polym.* **1994**, *22*, 243–258 and references therein. (d) Kates, S. A.; McGuinness, B. F.; Blackburn, C.; Griffin, G. W.; Solé, N. A.; Barany, G.; Albericio, A. “High Load” Polyethylene Glycol-Polystyrene (PEG-PS) Graft Supports for Solid-Phase Synthesis. *Pept. Sci. (Biopolym.)* **1998**, *47*, 365–380.
- (50) Kempe, M.; Barany, G. CLEAR: A Novel Family of Highly Cross-Linked Polymeric Supports for Solid-Phase Peptide Synthesis. *J. Am. Chem. Soc.* **1996**, *118*, 7083–7093. Maria Kempe and I acknowledge our debt to Lin Chen, who was completing his Ph.D. studies at the time, for the wonderful acronym which lends itself readily to all sorts of interesting slogans and double-entendres, e.g., “let’s make this perfectly CLEAR” or “the solution is CLEAR.” My memory has thankfully been purged of some of the less satisfactory earlier alternatives that we considered.
- (51) Barany, G.; Albericio, F.; Kates, S. A.; Kempe, M. Poly(ethylene Glycol)-Containing Supports for Solid-Phase Synthesis of Peptides and Combinatorial Organic Libraries. In *Poly(ethylene glycol): Chemistry and Biological Applications*; Harris, J. M., Zalipsky, S., Eds.; ACS Symposium Series 680; American Chemical Society: Washington, DC, 1997; pp 239–264.
- (52) (a) Barany, G.; Merrifield, R. B. A New Amino Protecting Group Removable by Reduction. Chemistry of the Dithiasuccinoyl (Dts) Function. *J. Am. Chem. Soc.* **1977**, *99*, 7363–7365. (b) Barany, G.; Merrifield, R. B. A Chromatographic Method for the Quantitative Analysis of the Deprotection of Dithiasuccinoyl (Dts) Amino Acids. *Anal. Biochem.* **1979**, *95*, 160–170. (c) Barany, G.; Merrifield, R.

- B. Kinetics and Mechanism of the Thiolytic Removal of the Dithiasuccinoyl (Dts) Amino Protecting Group. *J. Am. Chem. Soc.* **1980**, *102*, 3084–3095. (d) Barany, G. The Explicit Analysis of Consecutive Pseudo-First-Order Reactions: Application to Kinetics of Thiolytic Removal of Dithiasuccinoyl (Dts) Amino Acids. *Anal. Biochem.* **1980**, *109*, 114–122. (e) Barany, G. Chemistry of carbamoyl disulfide protected derivatives of proline. *Int. J. Pept. Protein Res.* **1982**, *19*, 321–324. (f) Barany, G.; Albericio, F. A Three-Dimensional Orthogonal Protection Scheme for Solid-Phase Peptide Synthesis under Mild Conditions. *J. Am. Chem. Soc.* **1985**, *107*, 4936–4942. (g) Albericio, F.; Barany, G. Mild, orthogonal solid-phase peptide synthesis: use of *N*^α-dithiasuccinoyl (Dts) amino acids and *N*-(isopropylidithio)carbonylproline, together with *p*-alkoxybenzyl ester anchoring linkages. *Int. J. Pept. Protein Res.* **1987**, *30*, 177–205. (h) Zalipsky, S.; Albericio, F.; Slomczynska, U.; Barany, G. A convenient general method for synthesis of *N*^α- or *N*^ω-dithiasuccinoyl (Dts) amino acids and dipeptides: application of poly(ethylene glycol) as a carrier for functional purification. *Int. J. Pept. Protein Res.* **1987**, *30*, 740–783. (i) Xu, Q.; Musier-Forsyth, K.; Hammer, R. P.; Barany, G. Use of 1,2,4-dithiazolidine-3,5-dione (DtsNH) and 3-ethoxy-1,2,4-dithiazoline-5-one for synthesis of phosphorothioate-containing oligodeoxyribonucleotides. *Nucleic Acids Res.* **1996**, *24*, 1602–1607. (j) Chen, L.; Barany, G. *N*-Dithiasuccinoyl (Dts)-glycine as an oxidation reagent for the formation of intramolecular disulfide bridges under mild conditions. *Lett. Pept. Sci.* **1996**, *3*, 283–292. (k) Planas, M.; Bardají, E.; Jensen, K. J.; Barany, G. Use of the Dithiasuccinoyl (Dts) Amino Protecting Group for Solid-Phase Synthesis of Protected Peptide Nucleic Acid (PNA) Oligomers. *J. Org. Chem.* **1999**, *64*, 7281–7289.
- (53) Merrifield and I (ref 52a) define an orthogonal system as two or more classes of groups that are removed by differing chemical mechanisms and therefore can be removed in any order and in the presence of the other classes, and we also pointed out how orthogonality was an avenue to milder schemes of peptide synthesis. Although the idea is implicit in what chemists have been doing for the better part of the 20th century, and its mathematical heritage is obvious, this was the first time that the term “orthogonal” appeared in print in this context. It is humbling to note how the language has been universally adopted, but few of its users are aware of its origins.
- (54) (a) Atherton, E.; Sheppard, R. C. *Solid-Phase Peptide Synthesis: A Practical Approach*; IRL Press: Oxford, 1989. (b) Fields, G.; Tian, Z.; Barany, G. Principles and Practice of Solid-Phase Peptide Synthesis. In *Synthetic Peptides: A User's Guide*; Grant, G. A., Ed.; W. H. Freeman & Co.: New York, 1992; pp 77–183. (c) *Fmoc Solid-Phase Peptide Synthesis: A Practical Approach*; Chan, W. C., White, P. D., Eds.; Oxford University Press: Oxford, U.K., 1999.
- (55) Miklos Bodanszky, an inventor of active ester technology and author of several seminal monographs and texts, has known me longer than anyone in the peptide field, since he was collaborating with my mother in Hungary back in 1954, when she was pregnant. Due to the 1956 revolution, we all followed our separate paths, his going through du Vigneaud's laboratory and Squibb before settling in Cleveland, where among many other things, he was Derek Hudson's postdoctoral supervisor.
- (56) Empty is not the same as clean. During my first weeks, I personally climbed inside the fume hoods and scraped off the canopy gobs of elemental sulfur accumulated by Professor Raymond Dodson's students. Ironic, since much of my non-peptide research during the years leading up to tenure involved “following my nose” and developing some novel and occasionally esoteric organosulfur chemistry, e.g., (a) Barany, G.; Mott, A. W. Chemistry of Bis-(alkoxycarbonyl)polysulfanes and Related Compounds. *J. Org. Chem.* **1984**, *49*, 1043–1051. (b) Mott, A. W.; Barany, G. A. New Method for the Synthesis of Unsymmetrical Trisulfanes. *Synthesis* **1984**, 657–660. (c) Schroll, A. L.; Barany, G. Novel Symmetrical and Mixed Carbamoyl and Amino Polysulfanes by Reactions of (Alkoxydichloromethyl)polysulfanyl Substrates with *N*-Methylaniline. *J. Org. Chem.* **1986**, *51*, 1866–1881. The starting point for these investigations was the need to develop reagents to effectively elaborate the Dts moiety, but they soon took on their own urgency and provided ready access to trisulfides (including the active ingredient of garlic) and higher poly(sulfanes).
- (57) Much of the chemistry that Fernando was testing for Dts applications, whether successful or not, eventually spun over to Fmoc chemistry and has indeed made a major impact. Although I was personally devastated when Fernando was called back to Barcelona after less than 2 years as a full-time postdoctoral fellow, in the end this turned out to be a blessing. Thus, over the next 6 years, he came to Minneapolis during almost all of his breaks from teaching and worked very intensely on his own and with my graduate students to finish ongoing projects and seed new ones. Fernando started a pipeline from Barcelona to Minneapolis which sent us several outstanding graduate students and postdoctoral fellows, and he also spent 2 years (1992 and 1993) at what was then known as the MilliGen Bioscience division of Millipore, the successor to Bioscience re-established on the East Coast. A significant portion of our scientific bibliographies overlap, and no one was prouder than I when Fernando received the 1994 Leonidas Zervas Award from the European Peptide Society.
- (58) D.H. comments: see comparison section for more explanations.
- (59) I have a high degree of respect for Wolfgang, who persevered to found his own company which has been successful in establishing the TentaGel line of supports that in many ways are very similar to PEG-PS and are even more widely used. Kit Lam, Michal Lebl, and others adapted TentaGel for the split-bead synthesis method in combinatorial chemistry because it is both a good material for synthesis and compatible with biological testing in aqueous milieu; all of the studies in the “shaving” paper of which I am very proud were conducted on TentaGel. See: Vágner, J.; Barany, G.; Lam, K. S.; Krchňák, V.; Sepetov, N. F.; Ostrem, J. A.; Strop, P.; Lebl, M. Enzyme-mediated spatial segregation on individual polymeric support beads: Application to generation and screening of encoded combinatorial libraries. *Proc. Natl. Acad. Sci. U.S.A.* **1996**, *93*, 8194–8199 and references therein.
- (60) Other memories are a blur, but nonetheless amusing in hindsight. I taught my class (having scheduled an exam for the next session, when I would be gone), headed to the Minneapolis airport, had my pocket picked while watching a Minnesota Twins playoff game in the lounge of the Newark airport, failed in my assignment to view the “Little Mermaid” since a vandal had temporarily decapitated her in the Copenhagen harbor, and was mesmerized by the Anita Hill–Clarence Thomas hearings which were playing at 3 a.m. local time on the only English-language TV station in the hotel.
- (61) Gerry, N. P.; Witowski, N. E.; Day, J.; Hammer, R. P.; Barany, G.; Barany, F. Universal DNA Microarray Method for Multiplex Detection of Low Abundance Point Mutations. *J. Mol. Biol.* **1999**, *292*, 251–262.
- (62) Rapp Polymere GmbH, Ernst Simon Strasse 9, D 72072 Tubingen, Germany. E-mail: rapp-polymere@t-online.de.
- (63) Rapp, W.; Bayer, E. Polystyrene – Immobilized PEG chains: Dynamics and application in peptide synthesis, immunology and chromatography. In *Poly(Ethylene Glycol) Chemistry, Biotechnical and Biomedical Applications*; Harris, M. J., Ed.; Plenum Press: New York, 1992; pp 325–345.
- (64) D.H. comments: Figure 5, lower left, shows both the earlier and later formulations.
- (65) Rapp, W.; Bayer, E. Ultrahigh-speed continuous flow peptide synthesis for preview synthesis-principles and application in up-scaling. In *Innovations and Perspectives in Solid-Phase Synthesis, Peptides, Polypeptides and Oligonucleotides*; Epton, R., Ed.; Intercept Ltd.: Andover, 1992; pp 259–266.
- (66) Rapp, W.; Fritz, H.; Bayer, E. Monosized 15 μm grafted microspheres for ultra high speed peptide synthesis. In *Peptides and Biology, Proceedings of the Twelfth American Peptide Symposium*; Smith J. A., Rivier, J. E., Eds.; ESCOM: Leiden, 1992; pp 529–530.
- (67) Eggenweiler, M.; Clausen, N.; Fritz, H.; Zhang, L.; Bayer, E. Comparative studies of Mono- and polydisperse polystyrene and polystyrene-poly(ethylene glycol) graft copolymer beads. In *Peptides 1994, Proceedings of the 23rd European Peptide Symposium*; Maya, H. L. S., Ed.; Escrom: Leiden, 1995; pp 275–276.
- (68) Rapp, W.; Wiesmüller, K. H.; Fleckenstein, B.; Gnau, V.; Jung, G. New tools for libraries: Macrobeads of 750 μm diameter and selective orthogonal functionalization of inner sites and outer surface of beads. In *Peptides 1994, Proceedings of the 23rd European Peptide Symposium*; Maya, H. L. S., Ed.; Escrom: Leiden, 1995; pp 87–89.
- (69) Rapp, W. PEG grafted polystyrene tentacle polymers: Physicochemical properties and application in chemical synthesis. In *Combinatorial Peptides and Nonpeptide Libraries*; Jung, G., Ed; VCH: Weinheim, 1996; pp 425–464.
- (70) Pursch, M.; Schlotterbeck, G.; Tseng, L. H.; Albert, K.; Rapp, W. Monitoring the reaction progress in combinatorial chemistry: ¹H MAS NMR Investigations on single macrobeads in the suspended state. *Angew. Chem., Int. Ed. Engl.* **1996**, *35*, 2867–2869.
- (71) Owen Gooding, Argonaut Technologies, 887 Industrial Road, Suite G, San Carlos, CA 94707. E-mail: Ogooding@argotech.com.
- (72) The consortium consisted of scientists from Merck, Pharmacia, SmithKline Beecham, Berlex, Abbott, Amgen, Sandoz, and Bristol-Myers Squibb.

- (73) Bayer, E.; Hemmasi, B.; Albert, K.; Rapp, W.; Dengler, M. Immobilized Polyoxyethylene, A New Support for Peptide Synthesis. *Peptides, Structure and Function*, Proceedings of the Eighth American Peptide Symposium; Hruby, V. J., Rich, D. H., Eds.; Pierce Chem. Comput. 1983; p 87–90.
- (74) A selection of the supports are commercially available as TentaGel (Rapp Polymere, Tubingen FRG) and ArgoGel (Argonaut Technologies, San Carlos, CA).
- (75) Alternative PS-PEG supports have been described: (a) Zalipsky, S.; Chang, J. L.; Albericio, F.; Barany, G. Preparation and applications of poly(ethylene glycol)-polystyrene graft resin supports for solid-phase peptide synthesis. *React. Polym.* **1994**, *22*, 243–258. (b) Renil, M.; Meldal, M. POEPOP and POEPS: Inert Polyethylene Glycol Cross-linked Polymeric Supports for Solid Synthesis. *Tetrahedron Lett.* **1996**, *37*, 24, 6185–6188. (c) Park, B. D.; Lee, H. I.; Ryoo, S. J.; Lee, Y. S. Convenient Method for Preparing Polystyrene having ω -Hydroxy Group: Its Application to the Synthesis of Polystyrene Glycol-Grafted Polystyrene Resin. *Tetrahedron Lett.* **1997**, *38* (4), 591–594. (d) Adams, J. H.; Cook, R. M.; Hudson, D.; Jammalamadaka, V.; Lyttle, M. H.; Songster, M. F. A reinvestigation of the Preparation, Properties, and Applications of Aminomethyl and 4-Methylbenzhydrylamine Polystyrene Resins. *J. Org. Chem.* **1998**, *63*, 3706–3716.
- (76) Bayer, E.; Rapp, W. Polystyrene-Immobilized PEG Chains. *Poly(Ethylene Glycol) Chemistry: Biotechnical and Biomedical Applications*; Harris, M., Ed.; Plenum Press: New York, 1992; p 325–345.
- (77) The initial report (ref 73) and all subsequent reports the authors are aware of indicate a benzylic linkage as shown in Lehhr, B.; Egelhaaf, H.-J.; Fritz, H.; Rapp, W.; Bayer, E.; Oelkrug, D. Molecular Solvation and Mobility in Polymer/Liquid Interphases. A Fluorescence Study on Polystyrene-Poly(ethylene glycol) Microbeads. *Macromolecules* **1996**, *29*, 7931–7936.
- (78) D.H. comments: Indeed, the article by Wolfgang Rapp in this Perspective does seem to be the first disclosure that the formulation changed to an ethyl attachment as a result of the instability of the benzyl ether linkage to acid. This modification was made in 1992, several years before the development of ArgoGel.
- (79) D.H. comments: More recently a TentaGel HL (high load) with a loading of 0.4–0.6 mmol/g has become available.
- (80) Gooding, O. W.; Baudart, S.; Deegan, T. L.; Heisler, K.; Labadie, J.; Newcomb, W. S.; J. W.; Porco, J. A.; van Eikeren, P. On the Development of New Poly(styrene-*oxyethylene*) Graft Copolymer Resin Supports for Solid-Phase Organic Synthesis. *J. Comb. Chem.* **1999**, *1*, 113–122.
- (81) Trifluoroacetic acid solutions are commonly used for cleavage of synthesized compounds from the resin. Any impurities liberated by such treatment end up as contaminants in the collected products.
- (82) This testing protocol has been adopted as part of our analytical testing on all ArgoGel products to ensure consistent quality.
- (83) (a) Ford, W. T.; Mohanrag, S.; Periyasamy, M. Nuclear Magnetic Resonance Spectral Analysis of Polymer-Supported Reagents and Catalysts. *Br. Polym. J.* **1984**, *16*, 179–187. (b) Look, G. C.; Holmes, C. P.; Chinn, J. P.; Gallop, M. A. Methods for Combinatorial Organic Synthesis: The Use of Fast ^{13}C NMR Analysis for Gel Phase Reaction Monitoring. *J. Org. Chem.* **1994**, *59*, 7588–7590. (c) For ^{19}F NMR, see: Svensson, A. Fex, T.; Kihlberg, J. Use of ^{19}F NMR Spectroscopy to Evaluate Reactions in Solid-Phase Organic Synthesis. *Tetrahedron Lett.* **1996**, *37*, 7649–7652.
- (84) (a) Fitch, W. L.; Detre, G.; Holmes, C. P.; Shoolery, J. M.; Keifer, P. A. High-Resolution ^1H NMR in Solid-Phase Organic Synthesis. *J. Org. Chem.* **1994**, *59*, 7955–7956. (b) Keifer, P. A. The Influence of Resin Structure, Tether Length, and Solvent upon the High-Resolution ^1H NMR Spectra of Solid-Phase-Synthesis Resins. *J. Org. Chem.* **1996**, *61*, 1558–1559.
- (85) Deegan, T. L.; Gooding, O. W.; Baudart, S.; Porco, J. A., Jr. Nonacidic Cleavage of Wang-Derived Ethers from Solid Support: Utilization of a mixed-Bed Scavenger for DDQ. *Tetrahedron Lett.* **1997**, *38*, 28, 4973–4976.
- (86) Bilodeau, M. T.; Cunningham, A. M. Solid-Supported Synthesis of Imidazoles: A Strategy for Direct Resin-Attachment to the Imidazole Core. *J. Org. Chem.* **1998**, *63*, 2800–2801.
- (87) (a) Porco, J. A., Jr.; Deegan, T. L.; Devonport, W.; Gooding, O. W.; Labadie, J. W.; MacDonald, A. A.; Newcomb, B. N.; van Eikeren, P. Automated chemical synthesis: chemistry development on the Nautilus 2400. *Drugs Future* **1998**, *23*, 71–78. (b) Dankwardt, S. M.; Smith, D. B.; Porco, J. A., Jr.; Nguyen, C. Solid-Phase Synthesis of N-Alkyl Sulfonamides. *Synlett* **1997**, 854–856.
- (88) (a) Swayze, E. E. Secondary Amide-based Libraries for Solid-Phase Organic Synthesis. *Tetrahedron Lett.* **1997**, *38*, 8465–8468. (b) Swayze, E. E. The Solid-Phase Synthesis of Trisubstituted 1,4-Diazabicyclo[4.3.0]nonan-one Scaffolds: On Bead Monitoring of Heterocycle Forming Reactions Using ^{15}N NMR. *Tetrahedron Lett.* **1997**, *38*, 8643–8646.
- (89) Ruhland, B.; Bombrun, A.; Gallop, M. A. Solid-Phase Synthesis of 4-Arylazetid-2-ones via Suzuki and Heck Cross-Coupling Reactions. *J. Org. Chem.* **1997**, *62*, 7820–7826.
- (90) Kearney, P. C.; Fernandez, M.; Flygare, J. A. Solid-Phase Synthesis of 2-Aminothiazoles. *J. Org. Chem.* **1998**, *63*, 196–200.
- (91) Armstrong, R. W.; Du, X. Synthesis of Benzofuran Derivatives on Solid Support via SmI_2 -Mediated Radical Cyclization. *J. Org. Chem.* **1997**, *62*, 5678–5679.
- (92) D.H. comments: The original Biosearch SAM 1 DNA synthesizers were derived from a prototype consisting of a Varian 5000 HPLC, stripped of most of its components, and a spherical 20 μm Vydac support packed in an HPLC guard column.
- (93) D.H. comments: My especial thanks to Steve Adams, who has moved on to greater topics, for his contribution to this Perspective; somehow he found time to do this. In my opinion, he was the first person to put together the whole package of components which permit efficient automated synthesis of DNA, the key enabling methodology without which modern biotechnology would not have been possible! As Steve graciously acknowledges, his work, too, would not have been possible without the ground-breaking contributions of others.
- (94) Reddy, M. P.; Michael, M. A.; Farrow, F.; Girgis, N. S. New and Efficient Solid Support for the Synthesis of Nucleic Acids. *Tetrahedron Lett.* **1994**, *35*, 5771–5774.
- (95) Matson, R. S.; Rampal, J. B.; Coassin, P. *J. Anal. Biochem.* **1994**, *217*, 306.
- (96) Augmented surface particles formed by and for chemical transformations.
- (97) Argonaut Technologies, 887 Industrial Rd., Suite G, San Carlos, CA 940070-9773. Tel: (650)-598-1350. URL: <http://www.argotech.com>.
- (98) The synonymous term “macroreticular” is also widely used.
- (99) Portions of this work have been described previously: Porco, J. A.; Deegan, T. L.; Devonport, W.; Gooding, O. W.; Heisler, K.; Labadie, J. W.; Newcomb, B. N.; Nguyen, C.; van Eikeren, P.; Wong, J.; Wright, P. Automated Chemical Synthesis: From Resins to Instruments. *Mol. Diversity* **1997**, *2*, 197–206.
- (100) (a) Abrams, I. M. High Porosity Polystyrene Cation Exchange Resins. *Ind. Eng. Chem.* **1956**, 1469–1472. (b) Meitzner, E. F.; Oline, J. A. Process for Preparing Macroreticular resins, Copolymers and Products of Said Process U.S. Patent Application 749,526 filed July 18, 1958; issued U.S. Patent 4,382,124 to Rohm and Haas Co., May 3, 1983. (c) Guyot, A. In *Synthesis and Separations Using Functional Polymers*; Sherrington, D. C., Hodge, P., Eds.; John Wiley & Sons: Toronto, 1988; p 1–42.
- (101) For a recent examination of commercially available MP polymers for solid-phase synthesis, see: Hori, M.; Gravert, D. J.; Wentworth, P., Jr.; Janda, K. D. Investigating Highly Cross-linked Macroporous Resins for Solid-Phase Synthesis. *Bioorg. Med. Chem. Lett.* **1998**, *8*, 2363–2368.
- (102) Sherrington, D. C. In *Preparation, Functionalization, and Characteristics of Polymer Supports*; Hodge, P., Sherrington, D. C., Eds.; John Wiley & Sons Ltd.: New York, 1980; p 1–82.
- (103) Companies known to offer this type of support include Pharmacia (Uppsala, Sweden), Perceptive Biosystems (Framingham, MA), and Biosearch Technologies (Novato, CA). D.H. comments further: Isn’t it funny how different spins can be put on what should be a matter of simple fact? As far as I am aware PE Biosystems (formerly Applied Biosystems, Inc.) is the only company that supplies macroreticular resins for DNA synthesis (see Andrus, this Perspective and associated references, as well as the patent literature). Pharmacia and what was Perceptive Biosystems sell analogous versions of materials where the surface is perfused by pores for rapid solvent exchange. These, too, are covered by patents, and their territories have been quite hotly debated. Biosearch Technologies does supply a variety of such resins, but not macroreticular PS resins specifically formulated for oligonucleotide synthesis!
- (104) (a) Sherrington, D. C. Preparation, Modification and Characterization of Polymer-supported Species *Br. Polym. J.* **1984**, *16*, 164–172. (b) Guyot, A.; Bartholin, M. Design and Properties of Polymers as Materials for Fine Chemistry. *Prog. Polym. Sci.* **1982**, *8*, 277–332. (c) Sherrington, D. C. Appendix in *Polymer-supported Reactions in Organic Synthesis*; Hodge, P., Sherrington, D. C., Eds.; J. Wiley & Sons: Chichester, U.K., 1980; p 471.
- (105) In some earlier communications this material was referred to as X203.

- (106) (a) Albright, R. L. Porous Polymers as an Anchor for Catalysis React. *Polymer* **1986**, *4*, 155–174. (b) Pore size distribution analysis was conducted by Adsorption Studies Lab, Morgantown, WV.
- (107) Given a surface area of 650 m²/g and a loading of 0.75 mmol/g, a simple calculation of loading density can be conducted assuming all loading is present at the surface. Thus, such a resin has a molecular density of 0.0093 molecules/Å² or approximately 1 molecule per 10 Å² of surface area.
- (108) Frenette, R.; Friesen, R. W. Biaryl Synthesis via Suzuki Coupling on a Solid Support. *Tetrahedron Lett.* **1994**, *35* (49), 9177–9180.
- (109) (a) Chang, Y. H.; Ford, W. T. Use of Highly Cross-linked Polystyrene Supports for Acylation and Alkylation of an Ester Enolate at Room Temperature. *J. Org. Chem.* **1981**, *46*, 5364–5371. (b) Kraus, M. A.; Patchornik, A. A Comparison of Various Cross-linked Polystyrenes as Diluting Media in Reactions of Ester Enolates. *J. Polym. Sci.* **1974**, *47*, 11–18.
- (110) Backes, B. J.; Ellman, J. A. Carbon–Carbon Bond-Forming Methods on Solid Support. Utilization of Kenner's Safety-Catch Linker. *J. Am. Chem. Soc.* **1994**, *116*, 11171–11172. In this work a lightly cross-linked macroporous polystyrene resin (derived from Amberlite XE-305) was utilized.
- (111) Manuscript in preparation.
- (112) PE Biosystems, 850 Lincoln Centre Dr., Foster City, CA 94404. Tel: (650) 638-5607. Fax: (650) 638-6071. E-mail: andrusan@pebio.com.
- (113) See segment by Steve Adams.
- (114) Meitzner, E.; Oline, J. Polymerization Processes and Products Therefrom. U.S. Patent No. 4,224,415.
- (115) McBride, L.; McCollum, C.; Davidson, S.; Efcavitch, J.; Andrus, A.; Lombardi, S. A New, Reliable Cartridge for the Rapid Purification of Synthetic DNA. *BioTechniques* **1988**, *6*, 362–367.
- (116) Andrus, A.; McCollum, C.; Zon, G. Automated System for Polynucleotide Synthesis and Purification. U.S. Patent Nos. 5,047,524 and 5,262,530.
- (117) McCollum, C.; Andrus, A., An Optimized Polystyrene Support for Rapid Efficient Oligonucleotide Synthesis. *Tetrahedron Lett.* **1991** *32*, 4069–72.
- (118) Baier, J.; Kauffman, J.; Mason, G.; Wang, J.; Wright, P.; Andrus, A. Synthesis and Purification in a Single Column on a High-Throughput Automated Oligonucleotide Production System. *BioTechniques* **1996**, *20*, 298–303.
- (119) Bayer Corporation, Inc., 1017 Main Campus Dr., Suite 1200, Raleigh, NC 27606. E-mail: joey.buettner.b@bayer.com.
- (120) Scott, J. K.; Smith, G. P. Searching for Peptide Ligands with an Epitope Library. *Science* **1990**, *249*, 386–390.
- (121) Cwirla, S. E.; et al. Peptides on Phage: A Vast Library of Peptides for Identifying Ligands. *Proc. Nat. Acad. Sci.* **1990**, *87*, 6378–6382.
- (122) Baumbach, G. A.; Hammond, D. J. Protein Purification Using Affinity Ligands Deduced from Peptide Libraries. *BioPharm* **1992**, *24*–35.
- (123) Buettner, J. A.; Dadd, C. A.; Baumbach, G. A.; Masecar, B. L.; Hammond, D. J. Chemically derived peptide libraries: a new resin and methodology for lead identification. *Int. J. Pept. Prot. Res.* **1996**, *47*, 70–83.
- (124) The compiler of this Perspective is lost in admiration for this acronym, which stands for peptide (or peptidomimetic) library immunoscreening chromatographic analysis (PELICAN) technique; he has also tried his best to convince the author to use “The Pelican Brief” as a title for his segment; but has failed!
- (125) J.B. comments: I would like to show my deepest appreciation to Yoshio Kato, Ph.D., and Robert Rosen, Ph.D., of TosoHaas for their resin chemistry assistance. Without their persistence and patience none of this work would have been possible.
- (126) Performed by Harry Tang of Vortec Products Co., Long Beach, CA.
- (127) Chemistry developed by Derek Hudson, Biosearch Technologies, Inc.
- (128) J.B. comments: Our collaboration with Professor Carol A. Haney at NCSU has greatly accelerated our bead-bound ligand deconvolution. My deepest thanks to Dr. Haney, her postdocs and students for their active participation in this project.
- (129) Biederman, K.; Lee, H.; Haney, C. A.; Kaczmarek, M.; Buettner, J. A. Optimization of Nanospray Ionization Technique. *J. Pept. Res.* **1999**, *53*, 234–243.
- (130) Lee, H.; Haney, C. A.; Buettner, J. A. Evaluation of Nanoflow Electrospray Ionization Performance for Bead-Bound Combinatorial Peptides, ASMS Conference, 1998.
- (131) Huang, P. Y.; Baumbach, G. A.; Dadd, C. A.; Buettner, J. A.; Hentsch, M.; Hammond, D. J.; Carbonell, R. G. Affinity purification of von Willebrand factor using ligands derived from peptide libraries. *Bioorg. Med. Chem.* **1996**, *4*, 699–708.
- (132) Tyler-Cross, R.; Sobel, M.; Marques, D.; Soler, D.; Harris, R. B. Heparin-von Willebrand Factor Binding as Assessed by Isothermal Titration Calorimetry and by Affinity Fractionation of Heparins Using Synthetic Peptides. *Arch. Biochem. Biophys.* **1993**, *306*, 528–533.
- (133) J.B. comments: Performed by Robert Harris, Ph.D., at Commonwealth Biotechnologies, Inc., Richmond, VA. Dr. Harris has provided insight and clarity to on-resin thermodynamics; much thanks to his group for their work.
- (134) Smith, G. P.; Schultz, D. A.; Ladbury, J. E. A Ribonuclease S-peptide Antagonist Discovered with a Bacteriophage Display Library. *Gene* **1993**, *128*, 37–42.
- (135) Huang, P. Y.; Carbonell, R. G. Affinity Purification of Proteins Using Ligands Derived from Peptide Libraries. *Biotechnol. Bioeng.* **1995**, *47*, 288–2.
- (136) J.B. comments: I would also like to thank David Hammond and George Baumbach for their guidance; Robert Harris, Carol Haney, and Derek Hudson for their advice and active collaborations; and the many others, within Bayer and elsewhere, who also contributed to various stages of this development.
- (137) Biogen Inc., 12 Cambridge Center, Cambridge, MA 02142. E-mail: steve_adams@biogen.com.
- (138) S.P.A. comments further: Concurrent with these developments, Gough, Brunden, and Gilham published a method for recovery of valuable phosphate diester starting materials as barium salts from spent coupling mixtures where they employed CPG as the support. However, they did not note any advantages with CPG in their method (Gough, G. R.; Brunden, M. J.; Gilham P. T. Recovery and Recycling of Synthetic Units in the Construction of Oligodeoxyribonucleotides on Solid Supports. *Tetrahedron Lett.* **1981**, *22*, 4177–4180).
- (139) Adams, S. P.; Kavka, K. S.; Wykes, E. J.; Holder, S. B.; Galluppi, G. R. Hindered Dialkylamino Nucleoside Phosphate Reagents in the Synthesis of Two DNA 51-mers. *J. Am. Chem. Soc.* **1983**, *105*, 661–663.
- (140) Cook, R. M.; Adams, J. H.; Hudson, D. The Preparation and Synthetic Applications of Heterobifunctional Biocompatible Spacer Arms. *Tetrahedron Lett.* **1994**, *35*, 6777–6780.
- (141) Hudson, D. This Perspective.
- (142) Fearon, K. L.; Hirschbein, B. L.; Chiu, C. Y.; Quijano, M. R.; Zon, G. Phosphorothioate Oligodeoxynucleotides: Large-Scale Synthesis and Analysis, Impurity Characterization, and the Effects of Phosphorus Stereochemistry. *Ciba Found. Symp.* **1997**, *209*, 19–37.
- (143) D.H. comments: Nicely exemplified in the section by B. A. Morgan.
- (144) S.P.A. comments further: One such application is for oligosaccharide synthesis; see, for example: (a) Adinolfi, M.; Barone, G.; De Napoli, L.; Iasonisi, A.; Piccialli, G. Use of controlled pore glass in solid phase oligosaccharide synthesis. Application to the semiautomated synthesis of a glyconucleotide conjugate. *Tetrahedron Lett.* **1998**, *39*, 1953–1956. (b) Heckel, A.; Mross, E.; Jung, K. H.; Rademann, J.; Schmidt, R. R. Oligosaccharide synthesis on controlled pore glass as solid-phase material. *Synlett* **1998**, 170.
- (145) Biomeasure Incorporated, 27, Maple Street, Milford MA 01757-3650. E-mail: Barry.Morgan@biomeasure.com.
- (146) Houghten, R. A.; et al. Simultaneous Multiple Peptide Synthesis. In *Peptides Chemistry and Biology, Proceedings of the 10th American Peptide Symposium*; Marshall, G., Ed.; ESCOM: Leiden, 1988; p 166.
- (147) Geysen H. M.; Rodda, S. J.; Mason, T. J. A Synthetic Strategy for Epitope Mapping. In *Peptides Chemistry and Biology, Proceedings of the 10th American Peptide Symposium*; Marshall, G., Ed.; ESCOM: Leiden, 1988; p 519.
- (148) Furka, A.; et al. General method for rapid synthesis of multicomponent peptide mixtures. *Int. J. Pept. Prot. Res.* **1991**, *37*, 487.
- (149) Ator, M. A.; et al. Immobilized Peptide Arrays: A New technology for the characterization of protease function. In *Peptides: Chemistry Structure and Biology, Proceedings of the 13th American Peptide Symposium*; Hodges, R., Smith, J., Eds.; 1994; p 1012.
- (150) Singh, J.; et al. Validation of Screening Immobilized Peptide Libraries for Discovery of Protease Substrates. *J. Med. Chem.* **1995**, *38*, 217.
- (151) D.H. comments: Since Paul does not relate this story, I cannot resist this opportunity to tell it, since it definitely does deserve a minor niche in recorded history. The Loma Prieta earthquake had just struck the Bay Area (1989, during the World Series). The next day Paul called me to relate how, although his laboratory in Palo Alto had been pretty thoroughly wrecked, his Biosearch 9600 had continued to work faultlessly, despite having been jolted across the room! He then followed this up by FAXing me an HPLC of the peptide it had made and that he had just cleaved. Bearing in mind that his wife and firstborn were in hospital at the time, I took this as being a remarkable testament to both him and the machine. I wrote the story

- up for the Milligen/Biosearch newsletter, but it was rejected, as it was thought not right to try to benefit from other people's misfortunes. Considering that I had lived through the trauma, too, although virtually unscathed (apart from one bottle of wine which shook off a bookcase), and the critics lived 3000 miles away, their comments seemed unjustified!
- (152) D.H. comments: In my opinion this idea had a seminal influence on all of the array variations that followed it (see, for example, the section by Barry Morgan for its impact on him).
- (153) D.H. comments: In the mid to late 1980s I gave a talk (about Fmoc chemistry) at Cetus (now Chiron) organized by Dee Nitecki as part of the influential Bay Area Peptide Club (alas, now dormant!). I happened to mention the Mario Geysen "pin-head" method, and the entire audience dissolved in laughter. Now I do like to entertain during a lecture, but I also like to appreciate the joke; I still don't get it!
- (154) Then at Applied Immunosciences; now at Ekagen, 969C Industrial Rd., San Carlos, CA 94070; happily still making new materials for biotechnology applications.
- (155) Presently at Hewlett-Packard Company, 2850 Centerville Rd., Wilmington, DE 19801. E-mail: paul_hoeprich@hp.com.
- (156) D.H. comments: When I undertook to write this Perspective I contacted several people involved in the development of the VLSIP's method. Paul has stepped to the plate admirably, and with characteristic restraint has chosen not to discuss how little recognition he has received for the several enabling contributions he made to the subject technology. This matter was supposed to have been rectified, in 1995, by his inclusion as an author on several key patent applications, but according to a recent search, this does not seem to have yet occurred.
- (157) Amit, B.; Zehavi, U.; Patchornik, A. *Isr. J. Chem.* **1974**, *12*, 103.
- (158) Robinson, A. B.; Tedroso, S. *Int. J. Pept. Protein Res.* **1973**, *5*, 275–278.
- (159) Fodor, S. P. A.; Read, J. L.; Pirrung, M. C.; Stryer, L.; Liu, A. T.; Solas, D. *Science* **1991**, *251*, 767–773.
- (160) Hudson, D.; Johnson, C. R.; Ross, M. J.; Shoemaker, K. R.; Cass, R. T.; Giebel, L. B. Thin Film HPMP Matrix Systems and Methods for Constructing and Displaying Ligands. U.S. Patent 5,576,220, 1996.
- (161) Hudson, D.; Johnson, C. R.; Giebel, L. Pilot Apparatus for Peptide Synthesis and Screening. U.S. Patent, 5,585,275, 1996.
- (162) D.H. comments: Ed Southern devised a somewhat related method for the synthesis of DNA arrays (reviewed by Pirrung, M. C. Spatially addressable Combinatorial Libraries. *Chem. Rev.* **1997**, *97*, 473–486); later versions produced by Peter Coassin of Beckman Instruments, Fullerton, CA, used a multichanneled device for these arrays with a remarkable resemblance to the Pilot reaction block.
- (163) D.H. comments further: And yes, as with Bruce Merrifield, the inspiration for this Pilot technology (peptide identification and lead optimization technique), did come, almost fully formed, in the middle of the night; but it took a second night to add the connection of mixture incorporation which converted it from a mere lead optimization method to a real library technique. I, too, found the processes involved in developing this idea to practicality difficult, but I, too, enjoy experimental work and was buoyed by the high points when one hurdle was passed. When things were going poorly I was likewise sustained by friendship, with Chuck Johnson, who worked hand in hand with me on the project at that time. The most difficult part of the whole business was dealing with a management structure which was divided on the topic of whether they really wanted this technology or not. By the time I had been successful, it was clear that the method was not needed at Arris, and I left to join Ron Cook and found Biosearch Technologies.
- (164) D.H. comments: Chuck Johnson took this on his own shoulders and, aided with some very generous and helpful advice from Jim Sparrow, made some very nice, unique materials. They proved, regrettably, not to have the necessary mechanical strength.
- (165) Chiron Technologies Pty Ltd., 11 Duerdin Street, Clayton, Victoria, Australia. E-mail: Stuart_Rodda@cc.chiron.com.
- (166) Geysen, H. M.; Meloen, R. H.; Barteling, S. J. Use of peptide synthesis to probe viral antigens for epitopes to a resolution of a single amino acid. *Proc. Natl. Acad. Sci. U.S.A.* **1984**, *81*, 3998–4002.
- (167) Geysen, H. M.; Rodda, S. J.; Mason, T. J.; Tribbick, G.; Schoofs, P. G. Strategies for epitope analysis using peptide synthesis. *J. Immunol. Methods* **1987**, *102*, 259–274.
- (168) Geysen, H. M.; Rodda, S. J.; Mason, T. J. A priori delineation of a peptide which mimics a discontinuous antigenic determinant. *Mol. Immunol.* **1986**, *23*, 709–715.
- (169) Geysen, H. M.; Rodda, S. J.; Mason, T. J. The delineation of peptides able to mimic assembled epitopes. In *Synthetic Peptides as Antigens*; Ciba Foundation Symposium 119; Porter, R., Whelan J., Eds.; Wiley: Chichester, 1986; pp 130–149.
- (170) Reece, J. C.; Geysen, H. M.; Rodda, S. J. Mapping the major human T helper epitopes of tetanus toxin. The emerging picture. *J. Immunol.* **1993**, *151*, 6175–6184.
- (171) Chiron Technologies Pty Ltd., 11 Duerdin Street, Clayton, Victoria, Australia. E-mail: joe_maeji@cc.chiron.com.
- (172) Mario's group at the Commonwealth Serum Laboratories (CSL), Melbourne, was originally called Project X in the first few years. It then became the Department of Molecular Immunology of CSL. Subsequently, a fully owned subsidiary called Coselco Mimotopes Pty Ltd. was formed, which after sale to Chiron Corporation in 1992 became Chiron Mimotopes Pty Ltd. Soon after Mario's departure in 1993, Chiron merged our operations with Richard Houghten's Multiple Peptide Systems in San Diego to form Chiron Mimotopes Peptide Systems. These two entities were later de-merged, and our name went back to Chiron Mimotopes, and currently, we are Chiron Technologies Pty Ltd. A rose by any other name...
- (173) Cambridge Research Biochemicals (now owned by Zeneca) had an exclusive licence to sell the Multipin System (the epitope mapping kit) and independently shifted to Fmoc chemistry some years before our group did.
- (174) Maeji, N. J.; Bray, A. M.; Geysen, H. M. Multipin Peptide Synthesis Strategy for T cell determinant analysis. *J. Immunol. Methods* **1990**, *134*, 23–33.
- (175) Bray, A. M.; Maeji, N. J.; Valerio, R. M.; Campbell, R. A.; Geysen, H. M. Direct Cleavage of Peptides from a Solid Support into Aqueous Buffer. Applications in Simultaneous Multiple Peptide Synthesis. *J. Org. Chem.* **1991**, *56*, 6659–6666.
- (176) An Australian marsupial that loves playing in the ceiling spaces and rooftops of homes.
- (177) Valerio, R. M.; Benstead, M.; Bray, A. M.; Campbell, R. A.; Maeji, N. J. Synthesis of Peptide Analogues Using the Multipin Peptide Synthesis Method *Anal. Biochem.* **1991**, *30*, 168–177.
- (178) Bray, A. M.; Jhingran, A. G.; Valerio, R. M.; Maeji, N. J. Simultaneous Multiple Synthesis of Peptide Amides by the Multipin Method. Application of Vapor-Phase Ammonolysis. *J. Org. Chem.* **1994**, *59*, 2197–2203.
- (179) Geysen, H. M.; Rodda, S. J.; Mason, T. M.; Tribbick, G.; Schoofs, P. G. Strategies for Epitope Analysis. *J. Immunol. Methods* **1987**, *102*, 259–274.
- (180) Maeji, N. J.; Bray, A. M.; Valerio, R. M.; Wang, W. Larger Scale Multipin Peptide Synthesis. *Pept. Res.* **1995**, *8*, 33–38.
- (181) Maeji, N. J.; Valerio, R. M.; Bray, A. M.; Campbell, R. A.; Geysen, H. M. Graft Supports used with the Multipin Method of Peptide Synthesis. *J. Reactive Polym.* **1994**, *22*, 203–212.
- (182) Illumina Inc., 9390 Towne Centre Drive, San Diego, CA 92121. E-mail: chanfeng@illumina.com.
- (183) Nicolau, K. C.; Xiao, X.-y.; Parandoosh, Z.; Senyei, A.; Nova, M. P. *Angew. Chem., Int. Ed. Engl.* **1995**, *34*, 2289.
- (184) Battaerd, H. A. J.; Tregear, G. W. *Graft Copolymers*. Interscience Publishers: a Division of John Wiley & Sons: New York, 1972.
- (185) Berg, R. H.; Almdal, Pedersen, W. B.; Holm, A.; Tam, J. P.; Merrifield, R. B. *J. Am. Chem. Soc.* **1989**, *111*, 8024.
- (186) Matchi, S.; Kamel, I. And Silverman, J. *J. Polym. Sci. Part A-1* **1970**, *8*, 3329.
- (187) Geysen, H. M.; Meloen, R. H.; Barteling, S. J. *Proc. Natl. Acad. Sci. U.S.A.* **1984**, *81*, 3998.
- (188) Zhao, C. F.; Xiao, X.-y.; Czarnik, A. W.; Lillig, J. Methods for Radiation Grafting to Polymeric Surfaces. U.S. patent pending.
- (189) Mitchell, A. R.; Kent, S. B.; Engelhard, M.; Merrifield, R. B. *J. Org. Chem.* **1978**, *43*, 2845.
- (190) Zaugg, H. E.; Martin, W. B. *Org. React.* **1965**, *14*, 52.
- (191) Xiao, X.-y.; Zhao, C. F.; Potash, H.; Nova, M. P. *Angew. Chem., Int. Ed. Engl.* **1997**, *36*, 780.
- (192) Zhao, C. F.; Shi, S. H.; Mir, D.; Hurst, D.; Li, R.; Xiao, X.-y.; Lillig, L.; Czarnik, A. W. Polystyrene grafted fluoropolymer MicroTubes: new supports for solid-phase organic synthesis with useful performance at high temperature. *J. Comb. Chem.* **1999**, *1*, 91–95.
- (193) Li, R.; Xiao, X.-y.; Czarnik, A. W. *Tetrahedron Lett.* **1998**, *39*, 8581.
- (194) Shi, S.; Xiao, X.-y.; Czarnik, A. W. A combinatorial Synthesis of Tyrphostins via the 'Directed Sorting' method. *Biotechnol. Bioeng. (Comb. Chem.)* **1998**, *61*, 7.
- (195) For an excellent review, please see IRORI's technical brief collected by Mendonca, A. J.; et al. Solid-Phase organic Synthesis using MicroKan and MicroTube reactors.
- (196) Bing Yan (Novartis), personal communication.

- (197) Czarnik, A. W. Solid-phase synthesis supports are like solvents. *Biotechnol. Bioeng. (Comb. Chem.)* **1998**, *61*, 77–79.
- (198) Zhao, C. F.; Parandoosh, Z.; David, G. S.; Knoles, S.; Xiao, X.-y.; Nova, M. P.; Czarnik, A. W. MicroTubes for Combinatorial Chemistry Synthesis and Solid-Phase Scintillation Proximity Assay. Poster for Discovery 98 (Emerging Technologies for Drug Discovery), May 18–21, 1998, San Diego.
- (199) Parandoosh, Z.; Nova, M. P. Pot Assays for Screening. *Gen. Eng. News* **1999**, *42*.
- (200) I would like to take this opportunity to thank my previous colleagues at IRORI, especially Xiao-Yi Xiao, ShuHao Shi, RongShi Li, Hui Zhuang, Wenbao Li, David Mir, David Hurst, Scott Estrard, and IRORI's engineering team lead by Mr. John Lillig. Thanks above all are due to Tony Czarnik, for his support and encouragement, first at IRORI, and now at Illumina.
- (201) Spyder Instruments, 9390 Towne Centre Drive, San Diego, CA 92121. E-mail: michal@5z.com.
- (202) Houghten, R. A. General method for the rapid solid-phase synthesis of large numbers of peptides: Specificity of antigen–antibody interaction at the level of individual amino acids. *Proc. Natl. Acad. Sci. U.S.A.* **1985**, *82*, 5131.
- (203) D.H. comments: Coming from Michal, this is high praise indeed!!!!
- (204) Stierandova, A. Thesis, Institute of Organic Chemistry and Biochemistry, Prague, Czech Republic, 1992.
- (205) Rinnova, M. Thesis, Institute of Organic Chemistry and Biochemistry, Prague, Czech Republic, 1997.
- (206) Merrifield, R. B. Solid-phase peptide synthesis. I. The synthesis of a tetrapeptide. *J. Am. Chem. Soc.* **1963**, *85*, 2149.
- (207) Frank, R.; Heikens, W.; Heisterberg-Moutsis, G.; Blöcker, H. A new general approach for the simultaneous chemical synthesis of large numbers of oligonucleotides: Segmental solid supports. *Nucl. Acid. Res.* **1983**, *11*, 4365.
- (208) Frank, R.; Döring, R. Simultaneous multiple peptide synthesis under continuous flow conditions on cellulose paper discs as segmental solid supports. *Tetrahedron* **1988**, *44*, 6031.
- (209) Frank, R. SPOT synthesis: An easy technique for the positionally addressable, parallel chemical synthesis on a membrane support. *Tetrahedron* **1992**, *48*, 9217.
- (210) The relevant references can be found in the recent review article: Lebl, M. Solid-phase synthesis on planar supports. *Biopolymers (Pept. Sci.)* **1998**, *47*, 397.
- (211) Eichler, J.; Bienert, M.; Stierandová, A.; Lebl, M. Evaluation of cotton as a carrier for solid-phase peptide synthesis. *Pept. Res.* **1991**, *4*, 296.
- (212) Eichler, J.; Bienert, M.; Sepetov, N. F.; Stolba, P.; Krchnák, V.; Smékal, O.; Gut, V.; Lebl, M. Cotton-carrier for solid-phase peptide synthesis. In *Innovations and Perspectives in Solid-Phase Synthesis*; Epton, R., Ed.; SPCC: Birmingham, 1990; p 337.
- (213) Flegel, M.; Rinnová, M.; Pánek, Z.; Lepsa, L.; Bláha, I. Use of gaseous ammonia for detachment of peptides from various carriers: Development of production process. In *Peptides: Chemistry, Structure and Biology, Proc. 14. APS*; Kaumaya, P. T. P., Hodges, R. S., Eds.; Mayflower Scientific Ltd.: Kingswinford, 1996; p 119. Rinnova M., Thesis, Institute of Organic Chemistry and Biochemistry, Prague, Czech Republic, 1997.
- (214) Copies of theses (in English) are available from the Dr. Michal Lebl or from Dr. Stierandova (now Safarova, A., Selectide HMR, Tucson, AZ).
- (215) Eichler, J.; Houghten, R. A. Identification of substrate-analogue trypsin inhibitors through the screening of synthetic peptide combinatorial libraries. *Biochemistry* **1993**, *32*, 11035.
- (216) Lebl, M.; Stierandová, A.; Eichler, J.; Bienert, M. Alternative carriers and methods in solid-phase synthesis. In *Peptides 90, Proc. 21. EPS*; Giralt, E., Andreu, D., Eds.; ESCOM, Leiden, 1991; p 153.
- (217) Stierandová, A.; Sepetov, N. F.; Nikiforovich, G. V.; Lebl, M. Sequence-dependent modification of Trp by the Pmc protecting group of Arg during TFA deprotection. *Int. J. Pept. Protein Res.* **1994**, *43*, 31.
- (218) Rinnová, M.; Jezek, J.; Malon, P.; Lebl, M. Comparative multiple synthesis of fifty linear peptides: Evaluation of cotton carrier vs T bag-benzhydrylamine resin. *Pept. Res.* **1993**, *6*, 88.
- (219) Eichler, J.; Furkert, J.; Bienert, M.; Rohde, W.; Lebl, M. Multiple peptide synthesis on cotton carriers: Elucidation and characterization of an antibody binding site of CRF. In *Peptides 90, Proc. 21. EPS*; Giralt, E., Andreu, D., Eds.; ESCOM, Leiden, 1991; p 156.
- (220) (a) Eichler, J.; Pinilla, C.; Chendra, S.; Appel, J. R.; Houghten, R. A. Synthesis of peptide libraries on cotton carriers: Methods and applications. In *Innovation and Perspectives in Solid-Phase Synthesis*; Epton, R., Ed.; Mayflower Worldwide Limited: Birmingham, 1994; p 227. (b) Eichler, J.; Houghten, R. A. Preparation of synthetic peptide combinatorial libraries on cotton carriers and their application to the identification of trypsin inhibitors. In *Peptides 1992, Proc. 22. EPS*; Schneider, C. H., Eberle, A. N., Eds.; ESCOM, Leiden, 1993; p 320.
- (221) (a) Stanková, M.; Wade, S.; Lam, K. S.; Lebl, M. Synthesis of combinatorial libraries with only one representation of each structure. *Pept. Res.* **1994**, *7*, 292. (b) Lebl, M. To Selectide Corporation. Combinatorial libraries having a predetermined frequency of each species of test compound. US Patent. 5,688,696. 1997.
- (222) Eichler, J.; Houghten, R. A.; Lebl, M. Inclusion volume solid-phase peptide synthesis. *J. Pept. Sci.* **1996**, *2*, 240.
- (223) Krchnák, V.; Vágner, J.; Safar, P.; Lebl, M. Noninvasive continuous monitoring of solid-phase peptide synthesis by acid–base indicator. *Collect. Czech. Chem. Commun.* **1988**, *53*, 2542. It is very important to understand the mechanism of the bromophenol blue (bb) monitoring to achieve successful results. Bromophenol blue serves as an indicator, i.e., only trace amounts of monitoring dye should be added. Bromophenol blue forms an ion pair with free amino group and turns blue. Elimination of the amino group (by acylation) decolorizes the dye, and bromophenol blue is released to the surrounding medium. Since bromophenol blue can decolorize itself (1 equiv of bb will turn solid support dark blue, 2 equiv will decolorize the support), the sensitivity of the test depends on the amount of the indicator used. We recommend to use about 1% of equivalent of bb in relation to amino groups available on the support. In this case, basically no change in coloration is observed until 99% of the coupling is completed. If 20% of amino groups would be “colorized” by bb, the color change would start at 80% complete coupling and color change would be complete at 90% coupling completion.
- (224) The coupling kinetics can be followed with bead type carriers at the level of an individual bead under a microscope.
- (225) (a) Lebl, M.; Stierandová, A.; Eichler, J.; Pátek, M.; Pokorny, V.; Jehnicka, J.; Mudra, P.; Zenisek, K.; Kalousek, J. An automated multiple solid-phase peptide synthesizer utilizing cotton as a carrier. In *Innovation and Perspectives in Solid-Phase Peptide Synthesis*; Epton, R., Ed.; Intercept Limited: Andover, 1992; p 251. (b) Bolf, J.; Eichler, J.; Jehnicka, J.; Kalousek, J.; Lebl, M.; Mudra, P.; Pokorny, V.; Stierandová, A.; Zenisek, K. To Ceskoslovenska Akademie Ved. Multiple synthesis of peptide(s) on solid carrier. U.S. Patents 5,202,418; 5,338,831; 5,342,585. 1993. (c) Pokorny, V.; Mudra, P.; Jehnicka, J.; Zenisek, K.; Pavlík, M.; Voburka, Z.; Rinnová, M.; Stierandová, A.; Lucka, A. W.; Eichler, J.; Houghten, R. A.; Lebl, M. Compas 242. New type of multiple peptide synthesizer utilizing cotton and tea bag technology. In *Innovation and Perspectives in Solid-Phase Synthesis*; Epton, R., Ed.; Mayflower Worldwide Limited: Birmingham, 1994, p 643.
- (226) Lebl, M. New technique for high-throughput synthesis. *Bioorg. Med. Chem. Lett.* **1999**, *9*, 1305.
- (227) (a) Lebl, M.; Gut, V.; Eichler, J. Continuous solid-phase synthesis. In *Peptides: Chemistry, Structure and Biology, Proc. 11. APS*; Rivier, J. E., Marshall, G. R., Eds.; ESCOM, Leiden, 1990; p 1059. (b) Lebl, M.; Eichler, J. Simulation of continuous solid-phase synthesis: Synthesis of methionine enkephalin and its analogues. *Pept. Res.* **1989**, *2*, 297.
- (228) Anonymous inventor. To Farbwerke Hoechst Aktiengesellschaft. Werkwijze voor het bereiden van peptiden. Holland Patent. 6808183. 1969.
- (229) Schwabacher, A.; Shen, Y.; Johnson, C. W. Fourier Transform Combinatorial Chemistry. *J. Am. Chem. Soc.*, in press.
- (230) Edwards, J. V., Batiste, S. L., Gibbins, B. M., Goheen, S. C., Synthesis of elastase recognition sequences on cotton, Poster abstract P435. In *Book of Abstracts*; 16th American Peptide Symposium; Minneapolis, 6/26–7/1/99.
- (231) Dolecková, L.; Pavlík, M.; Voburka, Z.; Rinnová, M.; Suttar, J.; Dyr, J. E. Characterization of binding sites of fibrin specific monoclonal antibodies using cotton-bound combinatorial libraries. In *Innovation and perspectives in Solid-Phase Synthesis & Combinatorial Libraries*; Epton, R., Ed.; Mayflower Scientific Limited: Birmingham, 1996, p 347.
- (232) Ball, C. P.; Barrett, A. G. M.; Poitout, L. F.; Smith, M. L.; Thorn, Z. E. Polymer backbone disassembly: Polymerisable templates and vanishing supports in high loading parallel synthesis. *Chem. Commun.* **1998**, 2453.
- (233) PE Biosystems, 500 Old Connecticut Path, Framingham, MA 01701. E-mail: Scott_Daniels@pbio.com.
- (234) Daniels, S. B.; Bernatowicz, M. S.; Coull, J. M.; Köster, H. Membranes as solid supports for peptide synthesis. *Tetrahedron Lett.* **1989**, *30*, 4345–4348.

- (235) Koester, H.; Coull, J. M. Membranes with bound oligonucleotides and peptides. U.S. Patent 4,923,901, 1990.
- (236) Bernatowicz, M. S.; Daniels, S. B.; Coull, J. M.; Kearney, T.; Neves, R. S.; Coassin, P. J.; Köster, H. Recent developments in solid-phase synthesis using the 9-fluorenylmethyloxycarbonyl (Fmoc) protecting group strategy. In *Current Research in Protein Chemistry: Techniques, Structure, and Function*; Villafranca, J. J., Ed.; Academic Press: San Diego, CA, 1990; p 63–77.
- (237) Daniels, S. B.; Wang, D.; Heden, J. Synthesis and applications of peptides constructed on polymeric membrane supports. In *Innovation and Perspective in Solid-Phase Synthesis*; Epton, R., Ed.; Intercept Limited: Andover, U.K., 1992; p 105–110.
- (238) Laursen, R. A.; Wang, Z. Multiple peptide synthesis on polypropylene membranes for rapid screening of bioactive peptides. *Peptide Res.* **1992**, *5*, 275–280.
- (239) Bernatowicz, M. S.; Kearney, T.; Neves, R. S.; Köster, H. An efficient method for racemization free attachment of 9-fluorenylmethyloxycarbonyl-amino acids to peptide synthesis supports. *Tetrahedron Lett.* **1989**, *30*, 4341–4344.
- (240) Fitzpatrick, R.; Goddard, P.; Stankowski, R.; Coull, J. Hydrophilic membrane supports for DNA synthesis. In *Innovation and Perspective in Solid-Phase Synthesis*; Epton, R., Ed.; Intercept Limited: Andover, U.K., 1994; p 157–162.
- (241) Geysen, H. M.; Meloen, R. H.; Barteling, S. J. Use of peptide synthesis to probe viral antigens for epitopes to a resolution of a single amino acid. *Proc. Natl. Acad. Sci. U.S.A.* **1984**, *82*, 3998–4002.
- (242) Houghten, R. A. General method for the rapid solid-phase synthesis of large numbers of peptides: Specificity of antigen–antibody interaction at the level of individual amino acids. *Proc. Natl. Acad. Sci. U.S.A.* **1985**, *82*, 5131–5135.
- (243) Fodor, S. P. A.; Read, J. L.; Pirrung, M. C.; Stryer, L.; Lu, A. T.; Solas, D. Light-directed, spatially addressable parallel chemical synthesis. *Science* **1991**, *251*, 767–773.
- (244) Frank, R. SPOT synthesis: An easy technique for the positionally addressable, parallel chemical synthesis on a membrane support. *Tetrahedron* **1992**, *48*, 9217–9232.
- (245) Gausepohl, H.; Boulin, C.; Kraft, M.; Frank, R. W. Automated multiple peptide synthesis. *Peptide Res.* **1992**, *5*, 315–320.
- (246) D.H. comments further: The original Biosearch, then owned by New Brunswick Scientific, had exclusive rights to this method; it would be correct to say that at the time we did not appreciate the potential value of this property.
- (247) Hudson, D. Methodological Implications of Simultaneous Solid-Phase peptide Synthesis. I. Comparison of Different Coupling Procedures. *J. Org. Chem.* **1988**, *53*, 617–624. There was a remarkable difference in the opinion of the two referees. One referee stated that this was “a much needed investigation...which explodes a number of myths surrounding the use of favorite methods or reagents”, whereas the other referee stated that “the results were expected and conformed...with the known data”. Fortunately, the editor agreed with the former assessment, apparently.
- (248) D.H. comments further: Yes, I am the individual to be blamed for the proliferation or alphabet soup of deprotection and cleavage cocktails. My original experiments, on removing the Mtr group from arginine, showed that both additives, ethane dithiol and thioanisole, accelerated cleavage; and mixtures were even better. As a matter of fact I just ran out of steam in an iterative series of experiments looking at combinations regarding cleavage efficiency and preserving peptide integrity: there were 19 different variations (reagents A to S, initially); reagent R proved the most generally efficacious. Later, others introduced their own variants, choosing, as with reagents B and K (the names they chose), to introduce an element of self-recognition.
- (249) D.H. comments: I had hoped that the studies might have given support for resurrecting Bates reagent, a coupling reagent introduced by Arnold Bates and George Kenner, which should have performed as well as the related BOP reagent of Castro, developed contemporaneously, but this expectation was not substantiated.
- (250) Weiss, M. A.; Markus, M. A.; Biancalana, S.; Dahl, C. E.; Keutmann, H. T.; Hudson, D. Ligand Selection Rules in the Classical Zinc Finger Motif. *J. Am. Chem. Soc.* **1991**, *113*, 6704–6706.
- (251) (a) Tan, R.; Chen, L.; Buettner, J. A.; Hudson, D.; Frankel, A. D. RNA recognition by an Isolated α -Helix. *Cell* **1993**, *73*, 1031–1040. (b) Calnan, B. J.; Tidor, B.; Biancalana, S.; Hudson, D.; Frankel, A. D. Arginine-Mediated RNA Recognition: The Arginine Fork. *Science* **1991**, *252*, 1167–1171.
- (252) Hudson, D. Methodological Implications of Simultaneous Solid-Phase Peptide Synthesis: A Comparison of Active Esters. *Pept. Res.* **1990**, *3*, 51–55.
- (253) The studies initially used the difficult ACP decapeptide test sequence for evaluation purposes. It was concluded that pepsin K and PS were comparable supports, that CPG behaved quite poorly, but that some alternative rigid materials, including a ceramic and an HPLC silica, performed very well indeed. Because of the limitations provided by their pore size, larger peptides could not be made as cleanly with these alternatives.
- (254) A recent study (Feng, Y.; Burgess, K. Private communication) of macrocyclization reactions shows, in the most difficult case, that spacer-arm PS-PEG's do give improved yields over other resins.
- (255) Contributed from Novartis Pharmaceutical Corporation, Res 138, Mail stop 1-3, 556 Morris Avenue, Summit, NJ 07901-1398. E-mail: bing.yan@pharma.novartis.com. Present address: Axys Advanced Technologies, 385 Oyster Point Blvd., South San Francisco, CA 94080.
- (256) Wilson, M. E.; Paech, K.; Zhou, W.-J.; Kurth, M. J. Solvent and reagent accessibility within oligo(ethylene glycol) ether (PEG) cross-linked polystyrene beads. *J. Org. Chem.* **1998**, *63*, 5094.
- (257) Fields, G. B.; Fields, C. G. Solvation effects in solid-phase peptide synthesis. *J. Am. Chem. Soc.* **1991**, *113*, 4202.
- (258) Cilli, E. M.; Oliveira, E.; Marchetto, R.; Nakaie, C. R. Correlation between solvation of peptide-resins and solvent properties. *J. Org. Chem.* **1996**, *61*, 8992.
- (259) Rapp, W. PEG grafted polystyrene tentacle polymers: Physicochemical properties and application in chemical synthesis. In *Combinatorial Peptide and Nonpeptide Libraries: A Handbook*; Jung, G., Ed.; VCH: Weinheim, 1996; pp 425–464.
- (260) Santini, R.; Griffith, M. C.; Qi, M. A measure of solvent effects on swelling of resins for solid-phase organic synthesis. *Tetrahedron Lett.* **1998**, *39*, 8951.
- (261) Merrifield, B. The role of the support in solid-phase peptide synthesis. *Br. Polym. J.* **1984**, *16*, 173.
- (262) Guyot, A. Synthesis and structure of polymer supports. In *Syntheses and separations using functional polymers*; Sherrington, D. C., Hodge, P., Eds.; **1988**; p 1–42.
- (263) Meldal, M. Properties of solid supports. *Methods Enzymol.* **1997**, *289*, 83–103.
- (264) Cainelli, G.; Contento, M.; Manoscalchi, F.; Plessi, L. Polymer-supported reagents: Polar effects in substrate selectivity. *J. Chem. Soc. Chem. Commun.* **1982**, 725.
- (265) Regen, S. L.; Dulak, L. Solid-phase cosolvents. *J. Am. Chem. Soc.* **1977**, *99*, 623.
- (266) Frechet, J. M. J.; de Smet, M. D.; Farrall, M. J. Application of phase-transfer catalysis to the chemical modification of cross-linked polystyrene resins. *J. Org. Chem.* **1979**, *44*, 1774.
- (267) Ruhland, B.; Bombrun, A.; Gallop, M. A. Solid-phase synthesis of 4-arylazetidin-2-ones via Suzuki and Heck cross-coupling reactions. *J. Org. Chem.* **1997**, *62*, 7820.
- (268) Burgess, K.; Lim, D. Resin type can have important effects on solid-phase asymmetric alkylation reactions. *J. Chem. Soc., Chem. Commun.* **1997**, 785.
- (269) Briggs, J. C.; Hodge, P. Potassium borohydride reductions of ketones absorbed into polymer supports: Stereochemical effects. *J. Chem. Soc., Chem. Commun.* **1988**, 310.
- (270) D.H. comments: See my introduction for a little fuller commentary.
- (271) Albericio, F.; Pons, M.; Pedroso, E.; Giralt, E. Comparative study of supports for solid-phase coupling of protected-peptide segments. *J. Org. Chem.* **1989**, *54*, 360.
- (272) Yan, B.; Kumaravel, G.; Anjaria, H.; Wu, A.; Pette, R.; Jewell, C. F., Jr.; Wareing, J. R. Infrared spectrum of a single resin bead for real-time monitoring of solid-phase reactions. *J. Org. Chem.* **1995**, *60*, 5736.
- (273) Yan, B.; Fell, J. B.; Kumaravel, G. Progression of organic reactions on resin supports monitored by single bead FTIR microspectroscopy. *J. Org. Chem.* **1996**, *61*, 7467.
- (274) Li, W.; Xiao, X.; Czarnik, A. W. Kinetic comparison of amide formation on various cross-linked polystyrene resins. *J. Comb. Chem.* **1999**, *1*, 127.
- (275) Li, W.; Yan, B. Effects of polymer supports on the kinetics of solid-phase organic reactions: A comparison of polystyrene and TentaGel-based resins. *J. Org. Chem.* **1998**, *63*, 4092.
- (276) Although the task has been far less simple than I envisioned when I wrote the introductory paragraph to Part I, Michael Songster, our resident computer “genius” at Biosearch Technologies, has continued to be an invaluable resource. This opus could not have been completed without his efforts and clear sight. Since this really is the

conclusion, I would also like to acknowledge my many mentors over the years who justifiably felt that I never listened very closely to their instructions: the late Henry Norman Rydon, of Exeter University, who taught me to be critical of my own work—a hard lesson, but an immensely valuable one; Miklos Bodanszky who saw that solid-phase synthesis would be a good avenue for me to take up; and George Kenner, who gave me the opportunity to do this—his inspiration still lives on. I have had the great fortune to collaborate with some far better scientists than I am: I thank you ALL for the excitement that you provided. I would also like to thank Ron Cook, who has provided the opportunity, over the years, for me to do good science in the context of a small commercial organization, which is quite unusual.

(277) Use of considerable quantities of mastic were necessary; the result is somewhat patchy. My apologies to those whose work has been

omitted, either due to miscommunication, oversight, or deadline problems.

- (278) Brocchini, S.; James, K.; Tangspasuthadol, V.; Kohn, J. A Combinatorial Approach for Polymer Design. *J. Am. Chem. Soc.* **1997**, *119*, 4553–4554.
- (279) Brocchini, S.; James, K.; Tangspasuthadol, V.; Kohn, J. Structure–Property correlations in a combinatorial library of degradable biomaterials. *J. Biomed. Mater. Res.* **1998**, *42*, 66–75.
- (280) Reynolds, C. H. Designing Diverse and Focused Combinatorial Libraries of Synthetic Polymers. *J. Comb. Chem.* **1999**, *1*, 297–306.
- (281) D.H. comments further: Michal Lebl obviously understood this need since cotton, although white, is really the ultimate “green” support!

CC990046S